



DuPage Water Commission

600 E. Butterfield Road, Elmhurst, IL 60126-4642
(630) 834-0100 Fax: (630) 834-0120

AGENDA

DUPAGE WATER COMMISSION

THURSDAY, JUNE 19, 2014
7:00 P.M.

600 EAST BUTTERFIELD ROAD
ELMHURST, IL 60126

- I. Call to Order and Pledge of Allegiance
- II. Roll Call
(Majority of the Commissioners then in Office—minimum 7)
- III. Public Comments (limited to 3 minutes per person)
- IV. Approval of Minutes
(Concurrence of a Majority of those Commissioners Present, provided there is a quorum—minimum 4)

RECOMMENDED MOTION: To approve the Minutes of the May 15, 2014 Regular Meeting of the DuPage Water Commission (Voice Vote).

- V. Treasurer's Report – May 2014
(Concurrence of a Majority of those Commissioners Present, provided there is a quorum—minimum 4)

RECOMMENDED MOTION: To accept the May 2014 Treasurer's Report (Voice Vote).

- VI. Committee Reports
 - A. Finance Committee
 1. Report of 6/1914 Finance Committee
 2. Request for Board Action: To Suspend the Purchasing Procedures of the Commission's By-Laws and Authorize the Upgrade of the Incode Accounting System from **Tyler Technologies at a cost not-to-exceed \$50,000.00.**
(TO SUSPEND PURCHASING PROCEDURES: 2/3 Majority of those Commissioners Present, provided there is a quorum - minimum 5)
(Concurrence of a Majority of the Appointed Commissioners—7)

All visitors must present a valid driver's license or other government-issued photo identification, sign in at the reception area and wear a visitor badge while at the DuPage Pumping Station.

RECOMMENDED MOTION: To Suspend the Purchasing Procedures of the Commission's By-Laws and Authorize the Upgrade of the Incode Accounting System from Tyler Technologies at a cost not-to- exceed \$50,000.00 (Roll Call).

3. Actions on Other Items Listed on 6/19/14 Finance Committee Agenda

B. Administration Committee

1. Report of 6/19/14 Administration Committee

2. Actions on Other Items Listed on 6/19/14 Administration Committee Agenda

C. Engineering & Construction Committee

1. Report of 6/19/14 Engineering & Construction Committee

2. Ordinance No. O-5-14: An Ordinance Determining the Prevailing Rate of Wages in DuPage County and Cook County **(No Cost Component)**

(TO APPROVE: Concurrence of a Majority of the Appointed Commissioners-7)

3. Resolution No. R-15-14: A Resolution Approving and Ratifying Certain Work Authorization Orders Under Quick Response Electrical Contract QRE-6/12 at the June 19, 2014, DuPage Water Commission Meeting **(Divane Bros. Electric Co. for a total cost of \$1,112.75)**

(TO APPROVE: Concurrence of a Majority of the Appointed Commissioners-7)

4. Resolution No. R-16-14: A Resolution Approving and Ratifying Certain Task Orders Under a Master Contract with AECOM **(estimated cost of \$250,000.00)**

(Affirmative Majority of the Appointed Commissioners, containing the votes of at least 1/3 of the County Appointed Commissioners and 40% of the Municipal Appointed Commissioners—3 County + 3 Muni+1=7)

5. Resolution No. R-17-14: A Resolution Awarding a Contract to Furnish and Deliver Manhole Frames and Lids **(Neenah Foundry Company for the unit prices set forth in its Contract/Proposal not-to-exceed \$37,800.00)**

(TO APPROVE: Concurrence of a Majority of the Appointed Commissioners-7)

6. Resolution No. R-18-14: A resolution Awarding a Contract for Vacuum Excavation Services **(R.A. Mancini, Inc. – not-to-exceed \$90,000.00)**

(TO APPROVE: Concurrence of a Majority of the Appointed Commissioners-7)

7. Request For Board Action: A Contract Agreement for Electrical Supply Consulting Services **(SPI Consulting Group – hourly rate of \$260.00 on an as-needed basis)**

(TO APPROVE: Concurrence of a Majority of the Appointed Commissioners-7)

RECOMMENDED MOTION: To adopt item numbers 2 through 7 under the Engineering & Construction Report section of the Agenda in a single group pursuant to the Omnibus Vote Procedures (Roll Call).

8. Actions on Other Items Listed on 6/19/14 Engineering & Construction Committee Agenda

VII. Accounts Payable

(Affirmative Majority of the Appointed Commissioners, containing the votes of at least 1/3 of the County Appointed Commissioners and 40% of the Municipal Appointed Commissioners—3 County + 3 Muni+1=7)

RECOMMENDED MOTION: To approve the Accounts Payable in the amount of \$7,973,743.47, subject to submission of all contractually required documentation, for invoices that have been received (Roll Call).

RECOMMENDED MOTION: To approve the Accounts Payable in the amount of \$833,900.00, subject to submission of all contractually required documentation, for invoices that have not yet been received but have been estimated (Roll Call).

VIII. Chairman's Report

IX. Omnibus Vote Requiring Majority Vote

X. Omnibus Vote Requiring Super-Majority or Special Majority Vote

XI. Old Business

XII. New Business

XIII. Executive Session

(Concurrence of a Majority of those Commissioners Present, provided there is a quorum—minimum 4)

RECOMMENDED MOTION: To go into Executive Session to discuss security procedures pursuant to 5 ILCS 120/2(c)(8), to discuss matters related to personnel pursuant to 5 ILCS 120/2(c)(1) and (2), to discuss acquisition of real estate pursuant to 5 ILCS 120/2(c)(5), to discuss pending, probable, or imminent litigation pursuant to 5 ILCS 120/2(c)(11), and/or to discuss minutes of closed meetings pursuant to 5 ILCS 120/2(c)(21) (Roll Call).

RECOMMENDED MOTION: To come out of Executive Session (Voice Vote).

XIV. Adjournment

(Concurrence of a Majority of those Commissioners Present, provided there is a quorum—minimum 4)

**MINUTES OF A MEETING OF THE
DUPAGE WATER COMMISSION
HELD ON THURSDAY, MAY 15, 2014
600 E. BUTTERFIELD ROAD
ELMHURST, ILLINOIS**

The meeting was called to order by Chairman Zay at 7:00 P.M.

Commissioners in attendance: J. Broda, L. Crawford, R. Furstenau, D. Loftus, W. Murphy, J. Pruyne, F. Saverino, P. Suess, and J. Zay

Commissioners Absent: C. Janc, D. Russo, M. Scheck, and J.B. Webb

Also in attendance: Treasurer D. Ellsworth, J. Spatz, C. Johnson, C. Peterson, T. McGhee, J. Rodriguez, M. Weed, F. Frelka, R. C. Bostick, E. Kazmierczak, and G. Gorski of Gorski & Good, LLP.

PUBLIC HEARING

Commissioner Loftus moved to open the Public Hearing regarding the Annual Budget and Appropriation Ordinance for the Fiscal Year Commencing May 1, 2014 and Ending April 30, 2015. Seconded by Commissioner Broda and unanimously approved by a Voice Vote.

All voted aye. Motion carried.

There being no comments, Commissioner Loftus moved to close the Public Hearing regarding the Annual Budget and Appropriation Ordinance for the Fiscal Year Commencing May 1, 2014 and Ending April 30, 2015. Seconded by Commissioner Broda and unanimously approved by a Voice Vote.

All voted aye. Motion carried.

PUBLIC COMMENT

None

APPROVAL OF MINUTES

Commissioner Murphy moved to approve the Minutes of the April 17, 2014 Regular Meeting, and the Minutes of the April 17, 2014 Executive Session Meeting of the DuPage Water Commission. Seconded by Commissioner Furstenau and unanimously approved by a Voice Vote.

All voted aye. Motion carried.

Minutes of the 5/15/14 Commission Meeting

TREASURER REPORT

Treasurer Ellsworth presented the April 2014 Treasurer's Report, consisting of ten pages, noting that pages 1 and 2 contained a brief summary of the report.

Treasurer Ellsworth pointed out the \$69.9 million of cash and investments on page 3, which reflected a decrease of about \$4.9 million from the previous month due to the \$6 million Northern Trust debt certificate payment. Treasurer Ellsworth also pointed out the schedule of investments on pages 4 through 8 totaling \$67.7 million and the market yield on the total portfolio showed 52 basis points which had decreased slightly from the prior month. On page 9, the statement of cash flows showed an increase in cash and investments by about \$5.0 million and operating activities increased cash by approximately \$8.5 million, roughly \$34.5 million of sales tax was received, and principal and interest debt payments on bonds totaled about \$38.6 million. On page 10, the monthly cash/operating report showed that the Commission had met or exceeded all of its reserve requirements and approximately \$33.0 million of outstanding debt in Table 3, Rows H and I.

Commissioner Suess moved to accept the April 2014 Treasurer's Report. Seconded by Commissioner Furstenau and unanimously approved by a Voice Vote.

All voted aye. Motion carried.

COMMITTEE REPORTS

Finance Committee – Reported by Commissioner Suess

Commissioner Suess reported that even though the Finance Committee did not have a quorum, the members present reviewed and recommended for approval all items listed on the Finance Committee Agenda.

Commissioner Suess moved to adopt Ordinance No. O-4-14: Annual Budget and Appropriation Ordinance for the Fiscal Year Commencing May 1, 2014 and Ending April 30, 2015. Seconded by Commissioner Murphy and unanimously approved by a Roll Call Vote.

Ayes: J. Broda, L. Crawford, R. Furstenau, D. Loftus, W. Murphy, J. Pruyn, F. Saverino, P. Suess, and J. Zay

Nays: None

Absent: C. Janc, D. Russo, M. Scheck, and J.B. Webb

Administration Committee – Reported by Commissioner Crawford

Commissioner Crawford reported that the Administration Committee had reviewed and recommended for approval all items listed on the Administration Committee Agenda. After Commissioner Crawford provided a brief summary, she welcomed any questions.

Minutes of the 5/15/14 Commission Meeting

Hearing none, Commissioner Crawford moved to authorize the Execution of a Consulting Agreement with Rory Group, LLC. for a one year period in an amount not to exceed \$18,000.00. Seconded by Commissioner Saverino and unanimously approved by a Roll Call Vote.

Ayes: J. Broda, L. Crawford, R. Furstenau, D. Loftus, W. Murphy, J. Pruyn, F. Saverino, P. Suess, and J. Zay

Nays: None

Absent: C. Janc, D. Russo, M. Scheck, and J.B. Webb

Engineering & Construction Committee – Reported by Commissioner Loftus

Commissioner Loftus reported that the Engineering & Construction Committee had reviewed and recommended for approval all action items listed on the Engineering & Construction Agenda. Commissioner Loftus referred to Item Number 4 and requested that the item be considered by two separate votes; 1) to suspend the purchasing procedures of the Commission By-Laws; and 2) to approve items 2 through 4 in a single group pursuant to the Omnibus Vote Procedures.

With no further discussion, Commissioner Loftus moved to Suspend the Purchasing Procedures of the Commission's By-Laws for item number 4. Seconded by Commissioner Furstenau and unanimously approved by a Roll Call Vote.

Ayes: J. Broda, L. Crawford, R. Furstenau, D. Loftus, W. Murphy, J. Pruyn, F. Saverino, P. Suess, and J. Zay

Nays: None

Absent: C. Janc, D. Russo, M. Scheck, and J.B. Webb

Commissioner Loftus moved to adopt item numbers 2 through 4 under the Engineering & Construction Report section of the Agenda in a single group pursuant to the Omnibus Vote Procedures. Seconded by Commissioner Furstenau and unanimously approved by a Roll Call Vote.

Ayes: J. Broda, L. Crawford, R. Furstenau, D. Loftus, W. Murphy, J. Pruyn, F. Saverino, P. Suess, and J. Zay

Nays: None

Absent: C. Janc, D. Russo, M. Scheck, and J.B. Webb

Item 2: Resolution No. R-12-14: A Resolution Approving and Ratifying Certain Task Orders Under a Master Contract with Baxter & Woodman, Inc. (Estimated at \$22,700.00)

Minutes of the 5/15/14 Commission Meeting

Item 3: Resolution No. R-14-14: A Resolution Approving the Award of a Contract for the Construction of the Joint Meter/Pressure Adjusting Station for the York Township Water Facility Service Area (No Cost Component)

Item 4: To authorize the emergency repair of High Lift Pump Motor #5 (Estimated cost not-to-exceed \$80,000.00)

ACCOUNTS PAYABLE

Commissioner Broda moved to approve the Accounts Payable in the amount of \$7,053,042.22, subject to submission of all contractually required documentation, for invoices that have been received. Seconded by Commissioner Murphy and unanimously approved by a Roll Call Vote.

Ayes: J. Broda, L. Crawford, R. Furstenau, D. Loftus, W. Murphy, J. Pruyn, F. Saverino, P. Suess, and J. Zay

Nays: None

Absent: C. Janc, D. Russo, M. Scheck, and J.B. Webb

Commissioner Murphy moved to approve the Accounts Payable in the amount of \$652,410.00, subject to submission of all contractually required documentation, for invoices that have not yet been received but have been estimated, as amended. Seconded by Commissioner Pruyn and unanimously approved by a Roll Call Vote:

Ayes: J. Broda, L. Crawford, R. Furstenau, D. Loftus, W. Murphy, J. Pruyn, F. Saverino, P. Suess, and J. Zay

Nays: None

Absent: C. Janc, D. Russo, M. Scheck, and J.B. Webb

CHAIRMAN'S REPORT

Chairman Zay reported that negotiations between the Commission and International Union of Operating Engineers Local 399 are ongoing and that staff had not received any proposal from Union 150 to date.

Chairman Zay concluded his report by wishing Commissioner Saverino a Happy Birthday.

OMNIBUS VOTE REQUIRING MAJORITY VOTE

None

OMNIBUS VOTE REQUIRING SUPER-MAJORITY OR SPECIAL MAJORITY VOTE

None

Minutes of the 5/15/14 Commission Meeting

OLD BUSINESS

General Manager Spatz informed the Commissioners that staff would be scheduling a meeting with representatives from Metra to try and resolve the water main break issue that occurred in the City of Itasca amicably.

NEW BUSINESS

None

EXECUTIVE SESSION

None

Commissioner Murphy moved to adjourn the meeting at 7:14 P.M. Seconded by Commissioner Broda and unanimously approved by a Voice Vote.

All voted aye. Motion carried.

DUPAGE WATER COMMISSION INTEROFFICE MEMORANDUM

TO: Chairman and Commissioners
FROM: Douglas Ellsworth, Treasurer
DATE: June 9, 2014
SUBJECT: TREASURER'S REPORT – MAY 31, 2014

I am pleased to report that I have reviewed and approved all journal entries and bank reconciliations for the month of May, 2014. I have also reviewed the monthly financial statements and budget status reports, and found them to be in order.

Summary of Cash & Investments (Page 4)

1. Cash and investments totaled \$72.5 million at June 30th, an increase of \$2.6 million over the previous month. The increase can be attributed to positive cash flow from operations and our sales tax receipt.
2. The balance in the BMO Harris checking account at April 30th was \$2.8 million, up from the \$2.2 million reported last month.
3. The BMO Harris money market account balance at month-end was \$8.9 million, a decrease of \$988,000 from the prior month.
4. The IIIT money market account used by PFM for investment purposes decreased by \$2.2 million during the month, for an ending balance of \$4.5 million. The decrease can be attributed to investment purchases.
5. Our investment in U.S. Treasuries increased by \$4.3 million, for a total of \$27.3 million. Our U.S. agency investments decreased slightly, for an ending balance of \$17.0 million. Holdings in municipal bonds increased \$1.0 million, bringing the total to \$5.5 million. Our commercial paper holdings remained relatively constant at \$6.6 million.
6. The current holdings of cash and investments are in compliance with the approved investment policy.
7. As previously mentioned, the Commission's cash and investment position is \$2.6 million higher than our balance at the start of the fiscal year. There was a lot of movement between accounts this month.
 - The sales tax account decreased by \$2.0 million for an ending balance of \$7.2 million. The \$2.0 million was transferred to the Long-Term Capital Reserve Fund to fully fund the year's commitment of \$175,000 per month.
 - The Long-Term Capital Reserve Account increased \$2.1 million due to a decision to fully fund the year's scheduled transfers. Besides the \$2.0 million transferred from the Sales Tax

account, \$100,000 was transferred from the General Account. The month end balance was \$5.8 million.

- The Operating Reserve Account increased \$3.0 million for a total of \$37.5 million. The increase can be attributed to positive cash flow from operations and the sales tax receipt.

The following table presents a summary of the changes in cash position by account.

Cash and Investments by Account

Account	Balance 4/30/2014	Balance 5/31/2014	YTD Increase (Decrease)
Operations & Maintenance	\$10,909,467	\$10,503,186	\$ (406,281)
Bond Interest	22,545	21,671	(874)
Bond Principal	1,164,550	1,176,300	11,750
General Account	10,573,642	10,433,327	(140,315)
Sales Tax	9,182,877	7,178,532	(2,004,345)
Operating Reserve	34,435,593	37,475,035	3,039,442
Long-Term Cap. Reserve	3,658,775	5,757,010	2,098,235
Total Cash & Investments	\$69,947,449	\$72,545,061	\$ 2,597,612

Schedule of Investments (Pages 5-9)

1. The average yield to maturity on the Commission's investments was 0.57%, up slightly over the 0.52% reported last month.
2. The portfolio is showing unrealized gains of \$68,490 at May 31st, compared to unrealized losses of \$47,728 at April 30th.
3. The amortized cost of our investments was \$69.7 million at June 30th, an increase of \$2.0 million over last month.

Statement of Cash Flows (Page 10)

1. The statement of cash flows shows a breakdown of the \$2.6 million increase in cash & investments since the beginning of the fiscal year.
2. Operating activities increased cash by \$1.4 million.
3. \$2.4 million of sales tax revenue was received.
4. Debt service payments totaled \$1.2 million.
5. Cash flow from Investment activity came in at a negative \$2,242 due to purchased interest on new investments and some losses on the sale of investments. On an accrual basis, investment earnings were a positive \$38,077 for the month.

Reserve Analysis (Page 11)

1. The reserve analysis report shows the commission has met or exceeded all reserve targets at May 31st.
2. The Operating Reserve account is \$322,694 over its target of \$37.2 million.
3. The O & M account has \$10.5 million, which is \$1.5 million higher than target.

4. There was \$31.9 million of debt outstanding at May 31st, a reduction of \$1.1 million from last month. For the year, \$1.1 million of debt has been retired.

Respectfully submitted,

A handwritten signature in cursive script, appearing to read "Douglas R. Ellsworth".

Douglas R. Ellsworth, CPA
Treasurer

DU PAGE WATER COMMISSION
 TREASURER'S REPORT
 SUMMARY OF CASH AND INVESTMENTS
 May 31, 2014

FUNDS CONSIST OF:	May 31, 2014	April 30, 2014	INCR. - (DECR.)
PETTY CASH	1,200.00	1,200.00	0.00
CASH AT HARRIS BANK	2,801,389.17	2,208,634.94	592,754.23
TOTAL CASH	2,802,589.17	2,209,834.94	592,754.23
IIIT MONEY MARKET FUNDS	4,487,140.46	6,728,861.46	(2,241,721.00)
BMO HARRIS MONEY MARKET FUNDS	8,898,567.75	9,886,726.99	(988,159.24)
U. S. TREASURY INVESTMENTS	27,267,572.05	22,938,117.65	4,329,454.40
U. S. AGENCY INVESTMENTS	16,993,762.41	17,136,212.07	(142,449.66)
MUNICIPAL BONDS	5,496,426.12	4,449,867.19	1,046,558.93
COMMERCIAL PAPER	6,599,003.21	6,597,828.63	1,174.58
CERTIFICATES OF DEPOSIT	-	-	0.00
TOTAL INVESTMENTS	69,742,472.00	67,737,613.99	2,004,858.01
TOTAL CASH AND INVESTMENTS	72,545,061.17	69,947,448.93	2,597,612.24
	May 31, 2014	April 30, 2014	% CHANGE
IIIT MONEY MARKET FUNDS	6.4%	9.9%	-33.3%
BMO HARRIS MONEY MARKET FUNDS	12.8%	14.6%	-10.0%
U. S. TREASURY INVESTMENTS	39.1%	33.9%	18.9%
U. S. AGENCY INVESTMENTS	24.4%	25.3%	-0.8%
MUNICIPAL BONDS	7.9%	6.6%	23.5%
COMMERCIAL PAPER	9.5%	9.7%	0.0%
CERTIFICATES OF DEPOSIT	0.0%	0.0%	N/A
TOTAL INVESTMENTS	100.1%	100.0%	3.0%

Note 1 - Investments are carried at amortized cost.

DU PAGE WATER COMMISSION
 INVESTMENTS
 (Unaudited)
 May 31, 2014

FUND SOURCE	COUPON RATE	PURCHASE DATE	MATURITY DATE		YIELD TO MATURITY (COST)	PAR VALUE	AMORTIZED COST	AMORTIZED DISCOUNT (PREMIUM)	PURCHASE PRICE	ACCRUED INTEREST 05/31/14
Water Fund Oper. & Maint. Acct. (01-1211.03)										
BMO Harris - Money Market	0.164%	05/31/14	06/01/14	1	0.164%	7,700,596.30	7,700,596.30	-	7,700,596.30	-
Revenue Bond Interest Account (01-1212)										
BMO Harris	0.000%	05/31/14	06/01/14		0.000%	\$ 21,671.45	\$ 21,671.45	\$ -	\$ 21,671.45	\$ -
Revenue Bond Principal (01-1213)										
BMO Harris	0.000%	05/31/14	06/01/14		0.000%	\$ 1,176,300.00	\$ 1,176,300.00	\$ -	\$ 1,176,300.00	\$ -
Water Fund General Account (01-1217 & 1217.01)										
IIIT - Money Market	0.030%	05/31/14	06/01/14	1	0.030%	4,433,919.64	4,433,919.64	-	4,433,919.64	-
Credit Agricole North America CP	0.000%	03/04/14	06/02/14	2	0.200%	1,000,000.00	999,994.17	513.34	999,480.83	-
BNP Paribas Finance Inc CP	0.000%	03/27/14	06/02/14	2	0.200%	2,000,000.00	1,999,990.56	613.89	1,999,376.67	-
Deutsche Bank Finl CP	0.000%	03/04/14	07/02/14	32	0.200%	1,000,000.00	999,784.72	611.11	999,173.61	-
Bank of Tokyo Mitsubishi CP	0.000%	03/27/14	07/02/14	32	0.200%	2,000,000.00	1,999,638.34	758.34	1,998,880.00	-
					0.128%	\$ 10,433,919.64	\$ 10,433,327.43	\$ 2,496.68	\$ 10,430,830.75	\$ -
Weighted Avg Maturity			10							

DU PAGE WATER COMMISSION
 INVESTMENTS
 (Unaudited)
 May 31, 2014

FUND SOURCE	COUPON RATE	PURCHASE DATE	MATURITY DATE		YIELD TO MATURITY (COST)	PAR VALUE	AMORTIZED COST	AMORTIZED DISCOUNT (PREMIUM)	PURCHASE PRICE	ACCRUED INTEREST 05/31/14
Sales Tax Funds (01-1230 & 01-1230.01)										
IIIT - Money Market	0.030%	05/31/14	06/01/14	1	0.030%	10,112.21	10,112.21	-	10,112.21	-
US Treasury Notes	2.375%	03/21/13	10/31/14	153	0.230%	375,000.00	378,321.63	(9,612.94)	387,934.57	774.46
US Treasury Notes	2.500%	09/05/13	03/13/15	286	0.390%	475,000.00	483,309.60	(7,332.00)	490,641.60	2,011.61
US Treasury Notes	1.750%	09/06/12	07/31/15	426	0.290%	300,000.00	305,086.94	(7,557.59)	312,644.53	1,754.83
US Treasury Notes	1.375%	11/29/12	11/30/15	548	0.350%	100,000.00	101,529.67	(1,513.30)	103,042.97	3.76
US Treasury Notes	1.375%	05/15/14	11/30/15	548	0.200%	225,000.00	228,955.05	(123.08)	229,078.13	8.45
US Treasury Notes	2.000%	01/30/13	01/31/16	610	0.440%	35,000.00	35,906.21	(715.27)	36,621.48	233.98
US Treasury Notes	2.000%	03/04/14	01/31/16	610	0.300%	170,000.00	174,799.86	(698.58)	175,498.44	1,136.46
US Treasury Notes	0.375%	02/04/14	01/31/16	610	0.310%	200,000.00	200,216.92	(40.89)	200,257.81	250.69
US Treasury Notes	2.000%	03/28/13	04/30/16	700	0.380%	100,000.00	103,086.72	(1,889.84)	104,976.56	173.91
US Treasury Notes	1.750%	04/04/14	05/31/16	731	0.540%	150,000.00	153,615.92	(286.42)	153,902.34	7.17
US Treasury Notes	3.250%	05/10/13	06/30/16	761	0.410%	150,000.00	158,827.34	(4,414.85)	163,242.19	2,046.96
US Treasury Notes	3.250%	05/22/13	06/30/16	761	0.440%	150,000.00	158,443.04	(4,037.43)	162,480.47	2,046.96
US Treasury Notes	3.250%	05/24/13	06/30/16	761	0.530%	200,000.00	211,608.47	(5,664.97)	217,273.44	2,729.28
US Treasury Notes	1.000%	02/27/14	08/31/16	823	0.490%	250,000.00	252,846.24	(308.06)	253,154.30	631.79
US Treasury Notes	0.875%	11/27/13	11/30/16	914	0.580%	250,000.00	251,795.94	(352.50)	252,148.44	5.98
US Treasury Notes	0.875%	10/31/13	11/30/16	914	0.620%	350,000.00	352,199.62	(507.41)	352,707.03	8.37
US Treasury Notes	1.000%	03/19/14	03/31/17	1,035	0.920%	150,000.00	150,323.57	(22.13)	150,345.70	254.10
Regional Trans Auth, IL Rev Bonds	1.064%	06/26/12	06/01/14	1	1.060%	165,000.00	165,000.00	-	165,000.00	877.80
MD ST Econ Dev Corp Rev Bonds	0.750%	10/31/12	06/01/15	366	0.730%	170,000.00	170,032.99	(52.01)	170,085.00	637.50
IL ST Unemployment Rev Bonds	5.000%	07/31/12	06/15/15	380	0.850%	200,000.00	208,556.26	(14,941.74)	223,498.00	4,611.11
OR ST GO Bonds	0.497%	02/13/13	08/01/15	427	0.500%	100,000.00	100,000.00	-	100,000.00	165.67
IN ST Bonds Tax Rev	0.919%	12/23/13	01/15/16	594	0.920%	150,000.00	150,000.00	-	150,000.00	520.77
Regional Trans Auth, IL Rev Bonds	0.550%	05/07/14	05/06/16	706	0.580%	200,000.00	199,868.51	4.51	199,864.00	73.33
CA ST Taxable GO Bonds	1.250%	10/22/13	11/01/16	885	1.090%	100,000.00	100,380.33	(88.67)	100,469.00	104.17
FHLMC Notes	0.625%	04/30/12	12/29/14	212	0.480%	750,000.00	750,635.99	(2,281.51)	752,917.50	1,979.17
Federal Home Loan Bank Bonds	0.500%	01/23/14	06/12/15	377	0.260%	275,000.00	275,692.79	(227.36)	275,920.15	645.49
FHLB (CALLABLE) Global Notes	0.375%	12/30/13	12/30/15	578	0.390%	150,000.00	149,964.41	9.41	149,955.00	235.94
Fannie Mae Global Notes	0.500%	02/14/13	03/30/16	669	0.540%	115,000.00	114,922.90	54.00	114,868.90	97.43
Fannie Mae Global Notes	0.500%	08/29/13	03/30/16	669	0.710%	150,000.00	149,432.09	231.59	149,200.50	127.08
FNMA Notes	1.250%	10/01/13	09/28/16	851	0.750%	70,000.00	70,806.93	(226.97)	71,033.90	153.13
FNMA Notes	1.250%	10/01/13	09/28/16	851	0.750%	105,000.00	106,229.71	(345.93)	106,575.64	229.69
Federal Home Loan Bank Bonds	1.625%	04/04/14	03/27/17	1,031	1.250%	155,000.00	156,428.74	(274.71)	156,703.45	447.78
HSBC USA Inc. CP	0.000%	02/27/14	08/25/14	86	0.370%	300,000.00	299,837.09	180.17	299,656.92	-
JP Morgan Securities CP	0.000%	02/27/14	09/25/14	117	0.370%	300,000.00	299,758.33	193.75	299,564.58	-
					0.511%	\$ 7,095,112.21	\$ 7,178,532.02	\$ (62,842.73)	\$ 7,241,374.75	\$ 24,984.82
					Weighted Avg Maturity					509

DU PAGE WATER COMMISSION
INVESTMENTS
(Unaudited)
May 31, 2014

FUND SOURCE	COUPON RATE	PURCHASE DATE	MATURITY DATE		YIELD TO MATURITY (COST)	PAR VALUE	AMORTIZED COST	AMORTIZED DISCOUNT (PREMIUM)	PURCHASE PRICE	ACCRUED INTEREST 05/31/14
Water Fund Operating Reserve (01-1218)										
IIIT - Money Market	0.030%	05/31/14	06/01/14	1	0.030%	31,918.04	31,918.04	-	31,918.04	-
US Treasury Notes	1.875%	03/30/12	06/30/15	395	0.580%	225,000.00	228,142.31	(5,101.91)	233,244.22	1,771.41
US Treasury Notes	1.875%	03/30/12	06/30/15	395	0.580%	650,000.00	659,077.77	(14,738.88)	673,816.65	5,117.40
US Treasury Notes	1.750%	09/06/12	07/31/15	426	0.330%	425,000.00	432,014.23	(7,628.29)	439,642.52	2,486.02
US Treasury Notes	1.750%	06/27/12	07/31/15	426	0.460%	550,000.00	558,260.64	(10,688.51)	568,949.15	3,217.20
US Treasury Notes	1.375%	05/15/14	11/30/15	548	0.200%	1,000,000.00	1,017,502.24	(544.64)	1,018,046.88	37.57
US Treasury Notes	2.125%	01/28/14	12/31/15	579	0.360%	775,000.00	796,540.24	(4,616.01)	801,156.25	6,915.06
US Treasury Notes	0.375%	02/04/14	01/31/16	610	0.310%	1,100,000.00	1,101,193.07	(224.90)	1,101,417.97	1,378.80
US Treasury Notes	2.000%	03/04/14	01/31/16	610	0.300%	1,350,000.00	1,388,116.55	(5,547.51)	1,393,664.06	9,024.86
US Treasury Notes	1.750%	05/15/14	05/31/16	731	0.380%	1,000,000.00	1,027,218.40	(633.16)	1,027,851.56	47.81
US Treasury Notes	1.000%	02/11/14	08/31/16	823	0.550%	465,000.00	469,682.62	(603.12)	470,285.74	1,175.14
US Treasury Notes	1.000%	08/29/13	08/31/16	823	0.820%	1,475,000.00	1,481,054.93	(2,011.48)	1,483,066.41	3,727.58
US Treasury Notes	1.000%	03/06/13	10/31/16	884	0.490%	1,500,000.00	1,518,330.05	(9,326.20)	1,527,656.25	1,304.35
US Treasury Notes	4.625%	01/10/14	02/15/17	991	0.920%	425,000.00	466,958.74	(5,969.97)	472,928.71	5,755.70
US Treasury Notes	1.000%	02/27/14	03/31/17	1,035	0.730%	1,825,000.00	1,838,654.34	(1,173.79)	1,839,828.13	3,091.53
US Treasury Notes	1.000%	03/19/14	03/31/17	1,035	0.920%	1,850,000.00	1,853,990.69	(272.98)	1,854,263.67	3,133.88
US Treasury Notes	0.625%	05/15/14	05/31/17	1,096	0.830%	1,000,000.00	994,076.03	91.65	993,984.38	17.08
US Treasury Notes	0.625%	03/12/13	05/31/17	1,096	0.720%	1,100,000.00	1,097,058.38	1,183.38	1,095,875.00	18.78
US Treasury Notes	0.500%	08/15/12	07/31/17	1,157	0.740%	100,000.00	99,603.34	236.16	99,367.18	105.87
US Treasury Notes	0.625%	10/31/12	09/30/17	1,218	0.750%	300,000.00	298,810.02	708.46	298,101.56	317.62
US Treasury Notes	0.750%	11/01/12	10/31/17	1,249	0.740%	100,000.00	100,040.35	196.55	99,843.80	65.22
US Treasury Notes	0.625%	11/05/12	10/31/17	1,249	0.740%	175,000.00	175,070.61	343.96	174,726.65	114.13
US Treasury Notes	0.625%	05/09/14	11/30/17	1,279	1.180%	675,000.00	662,253.49	226.15	662,027.34	11.53
US Treasury Notes	0.750%	03/08/13	02/28/18	1,369	0.850%	1,500,000.00	1,494,503.28	1,768.90	1,492,734.38	2,843.07
US Treasury Notes	0.625%	05/10/13	04/30/18	1,430	0.810%	625,000.00	620,492.99	1,181.47	619,311.52	339.67
Regional Trans Auth, IL Rev Bonds	1.064%	06/26/12	06/01/14	1	1.060%	100,000.00	100,000.00	(457.00)	100,457.00	532.00
Regional Trans Auth, IL Rev Bonds	1.064%	06/26/12	06/01/14	1	1.060%	185,000.00	185,000.00	(845.45)	185,845.45	984.20
Regional Trans Auth, IL Rev Bonds	1.064%	06/26/12	06/01/14	1	1.060%	200,000.00	200,000.00	(914.00)	200,914.00	1,064.00
MD ST Econ Dev Corp Rev Bonds	0.750%	10/31/12	06/01/15	366	0.730%	120,000.00	120,023.29	(30.71)	120,054.00	450.00
MD ST Econ Dev Corp Rev Bonds	0.750%	10/31/12	06/01/15	366	0.730%	270,000.00	270,052.40	(69.10)	270,121.50	1,012.50
MD ST Econ Dev Corp Rev Bonds	0.750%	10/31/12	06/01/15	366	0.730%	300,000.00	300,058.22	(76.78)	300,135.00	1,125.00
IL ST Unemployment Rev Bonds	5.000%	07/31/12	06/15/15	380	0.850%	200,000.00	208,556.26	(11,391.74)	219,948.00	4,611.11
OR ST GO Bonds	0.497%	02/13/13	08/01/15	427	0.500%	135,000.00	135,000.00	41.85	134,958.15	223.65
IN ST Bonds Tax Rev	0.919%	12/23/13	01/15/16	594	0.920%	350,000.00	350,000.00	-	350,000.00	1,215.12
CA ST GO Bonds	1.050%	03/27/13	02/01/16	611	0.930%	275,000.00	275,547.10	(382.40)	275,929.50	962.50
Regional Trans Auth, IL Rev Bonds	0.550%	05/07/14	05/06/16	706	0.580%	850,000.00	849,441.15	19.15	849,422.00	311.67
IL ST Unemployment Rev Bonds	5.000%	07/31/12	06/15/16	746	1.050%	100,000.00	107,939.93	(5,898.07)	113,838.00	2,305.56
IL ST Unemployment Rev Bonds	5.000%	07/31/12	06/15/16	746	1.050%	300,000.00	323,819.79	(17,694.21)	341,514.00	6,916.67
IN ST Bond Bank Txbi Rev Bonds	1.022%	06/05/13	07/15/16	776	1.020%	275,000.00	275,000.00	-	275,000.00	1,061.74
CA ST Taxable GO Bonds	1.750%	10/22/13	11/01/17	1,250	1.660%	700,000.00	702,149.89	(349.11)	702,499.00	1,020.83

DU PAGE WATER COMMISSION
INVESTMENTS
(Unaudited)
May 31, 2014

FUND SOURCE	COUPON RATE	PURCHASE DATE	MATURITY DATE		YIELD TO MATURITY (COST)	PAR VALUE	AMORTIZED COST	AMORTIZED DISCOUNT (PREMIUM)	PURCHASE PRICE	ACCRUED INTEREST 05/31/14
Water Fund Operating Reserve (01-1218) Continued...										
Fannie Mae Global Notes	0.375%	03/30/12	03/16/15	289	0.600%	275,000.00	274,505.79	(749.68)	275,255.47	214.84
Freddie Mac Global Notes	0.500%	07/30/12	08/28/15	454	0.470%	630,000.00	630,240.36	(1,148.16)	631,388.52	796.25
FHLB (CALLABLE) Global Notes	0.375%	12/30/13	12/30/15	578	0.390%	675,000.00	674,839.84	42.34	674,797.50	1,061.72
Fannie Mae Global Notes	0.500%	02/14/13	03/30/16	669	0.540%	270,000.00	269,818.99	105.19	269,713.80	228.78
Fannie Mae Global Notes	0.500%	02/14/13	03/30/16	669	0.540%	540,000.00	539,637.97	210.37	539,427.60	457.50
Freddie Mac Global Notes	0.500%	03/07/13	05/13/16	713	0.500%	960,000.00	959,964.18	21.78	959,942.40	240.00
FHLMC Notes	2.500%	03/30/12	05/27/16	727	0.960%	200,000.00	206,045.29	(6,433.11)	212,478.40	55.56
FHLMC Notes	2.500%	03/30/12	05/27/16	727	0.960%	500,000.00	515,113.23	(16,082.77)	531,196.00	138.89
FNMA Notes	1.250%	03/30/12	09/28/16	851	1.060%	200,000.00	200,847.60	(3,558.60)	204,406.20	437.50
FNMA Notes	1.250%	03/30/12	09/28/16	851	1.060%	500,000.00	502,118.99	(8,896.51)	511,015.50	1,093.75
FHLMC Notes	0.875%	10/01/13	10/14/16	867	0.770%	1,000,000.00	1,002,382.53	(657.47)	1,003,040.00	1,142.36
Federal Home Loan Bank Bonds	1.625%	04/04/14	03/27/17	1,031	1.250%	655,000.00	661,037.59	(1,160.86)	662,198.45	1,892.22
Freddie Mac Global Notes	1.000%	10/31/13	06/29/17	1,125	0.960%	800,000.00	800,945.89	(174.11)	801,120.00	3,377.78
Freddie Mac Global Notes	1.000%	07/31/12	07/28/17	1,154	0.860%	125,000.00	125,533.26	(208.99)	125,742.25	427.08
Freddie Mac Global Notes	1.000%	07/31/12	07/28/17	1,154	0.860%	300,000.00	301,279.82	(501.58)	301,781.40	1,025.00
Fannie Mae Global Notes	0.875%	09/06/12	08/28/17	1,185	0.820%	200,000.00	200,326.34	404.34	199,922.00	442.36
Fannie Mae Global Notes	0.875%	09/06/12	08/28/17	1,185	0.820%	475,000.00	475,775.06	960.31	474,814.75	1,050.61
Fannie Mae Global Notes	0.875%	11/27/13	10/26/17	1,244	0.820%	1,300,000.00	1,291,296.53	1,241.53	1,290,055.00	1,105.90
Freddie Mac Global Notes	0.875%	03/27/13	03/07/18	1,376	0.930%	450,000.00	449,090.47	278.47	448,812.00	918.75
Freddie Mac Global Notes	0.875%	03/12/13	03/07/18	1,376	1.020%	1,100,000.00	1,093,930.44	1,916.44	1,092,014.00	2,245.83
Fannie Mae Global Notes	0.875%	05/24/13	05/21/18	1,451	0.540%	500,000.00	493,913.18	1,488.18	492,425.00	121.53
Fannie Mae Global Notes	0.875%	05/22/13	05/21/18	1,451	0.540%	1,000,000.00	993,240.32	1,690.32	991,550.00	243.06
					0.718%	\$ 37,236,918.04	\$ 37,475,035.05	\$ (132,404.81)	\$ 37,607,439.86	\$ 94,531.10
					Weighted Avg Maturity					901

DU PAGE WATER COMMISSION
INVESTMENTS
(Unaudited)
May 31, 2014

FUND SOURCE	COUPON RATE	PURCHASE DATE	MATURITY DATE		YIELD TO MATURITY (COST)	PAR VALUE	AMORTIZED COST	AMORTIZED DISCOUNT (PREMIUM)	PURCHASE PRICE	ACCRUED INTEREST 05/31/14	
Water Fund L-T Water Capital Reserve (01-1219)											
IIIT - Money Market (PFM Asset Management)	0.030%	05/31/14	06/01/14	1	0.030%	11,190.57	11,190.57	-	11,190.57	-	
US Treasury Notes	2.750%	10/21/13	11/30/16	914	0.690%	160,000.00	168,144.62	(1,974.13)	170,118.75	12.02	
US Treasury Notes	2.750%	12/13/13	11/30/16	914	0.670%	170,000.00	178,763.39	(1,622.55)	180,385.94	12.77	
US Treasury Notes	0.875%	12/26/13	02/28/17	1,004	0.910%	460,000.00	459,596.14	63.33	459,532.81	1,017.19	
US Treasury Notes	1.000%	03/17/14	03/31/17	1,035	0.790%	175,000.00	176,038.91	(75.35)	176,114.26	296.45	
US Treasury Notes	1.000%	04/11/14	03/31/17	1,035	0.780%	175,000.00	176,055.99	(51.43)	176,107.42	296.45	
US Treasury Notes	0.625%	08/13/13	05/31/17	1,096	1.030%	180,000.00	177,843.96	565.05	177,278.91	3.07	
US Treasury Notes	0.625%	05/15/14	05/31/17	1,096	0.850%	185,000.00	183,783.66	127.80	183,655.86	3.16	
US Treasury Notes	0.625%	02/05/14	05/31/17	1,096	0.820%	420,000.00	417,544.25	38.00	417,506.25	7.17	
US Treasury Notes	0.625%	05/15/14	11/30/17	1,279	1.030%	425,000.00	419,051.89	78.26	418,973.63	7.26	
US Treasury Notes	0.750%	12/31/13	02/28/18	1,369	1.380%	485,000.00	473,954.76	1,193.43	472,761.33	919.26	
US Treasury Notes	0.625%	05/13/13	04/30/18	1,430	0.820%	180,000.00	178,630.21	359.90	178,270.31	97.83	
US Treasury Notes	0.625%	05/15/13	04/30/18	1,430	0.820%	180,000.00	178,646.22	354.81	178,291.41	97.83	
Freddie Mac Global Notes	1.000%	02/11/14	06/29/17	1,125	0.960%	175,000.00	175,229.83	(22.17)	175,252.00	738.89	
Freddie Mac Global Notes	1.000%	10/31/13	06/29/17	1,125	0.960%	200,000.00	200,236.47	(43.53)	200,280.00	844.44	
Fannie Mae Global Notes	0.875%	12/26/13	10/26/17	1,244	1.310%	460,000.00	453,339.63	823.83	452,515.80	391.32	
Fannie Mae Global Notes	0.875%	05/15/14	05/21/18	1,451	1.300%	425,000.00	417,975.16	76.91	417,898.25	103.30	
Fannie Mae Global Notes	1.875%	05/15/14	09/18/18	1,571	1.410%	425,000.00	433,205.39	(82.11)	433,287.50	1,615.89	
Fannie Mae Global Notes	1.625%	12/31/13	11/27/18	1,641	1.780%	475,000.00	471,887.70	279.20	471,608.50	85.76	
Fannie Mae Benchmark Notes	1.875%	05/15/14	02/19/19	1,725	1.550%	400,000.00	405,891.00	(53.00)	405,944.00	2,125.00	
					1.141%	\$ 5,766,190.57	\$ 5,757,009.75	\$ 36.25	\$ 5,756,973.50	\$ 8,675.06	
					Weighted Avg Maturity					1,293	
					TOTAL ALL FUNDS	0.570%	\$ 69,430,708.21	\$ 69,742,472.00	\$ (192,714.61)	\$ 69,935,186.61	\$ 128,190.98
May 31, 2014					90 DAY US TREASURY YIELD	0.04%					
					3 month US Treasury Bill Index	0.03%		Longest Maturity	1,641	\$ 475,000.00	
					0-3 Year US Treasury Index	0.27%					
					1-3 Year US Treasury Index	0.35%					
					1-5 Year US Treasury Index	0.68%					

DUPAGE WATER COMMISSION
ELMHURST, ILLINOIS
TREASURER'S REPORT
STATEMENT OF CASH FLOWS
For the Fiscal Year Ended April 30, 2015

CASH FLOWS FROM OPERATING ACTIVITIES

Cash received from customers	\$ 8,981,986
Cash payments to suppliers	(7,384,236)
Cash payments to employees	(217,544)
Net cash from operating activities	<u>1,380,206</u>

CASH FLOWS FROM NONCAPITAL
FINANCING ACTIVITIES

Cash received from sales taxes	2,416,637
Cash Received from water quality loans	0
Net cash from noncapital financing activities	<u>2,416,637</u>

CASH FLOWS FROM CAPITAL AND
RELATED FINANCING ACTIVITIES

Interest paid	(21,385)
Principal Paid	(1,164,458)
Construction and purchase of capital assets	(11,146)
Net cash from capital and related financing activities	<u>(1,196,989)</u>

CASH FLOWS FROM INVESTING ACTIVITIES

Investment income	(2,242)
Net cash from investing activities	<u>(2,242)</u>

Net Increase (Decrease) in cash and investments 2,597,612

CASH AND INVESTMENTS, APRIL 30, 2014 69,947,449

CASH AND INVESTMENTS, MAY 31, 2014 \$ 72,545,061

May 31, 2014
 TREASURER'S REPORT
 DPWC MONTHLY CASH/OPERATING REPORT

	5/31/2014		
	YEAR END TARGETED Reserve or Monthly Cash Amount-Needed	Amount On Hand	Amount Over - (Under) Target
	A	B	C
TABLE 1			
RESERVE ANALYSIS			
A. Operating Reserve	\$ 37,152,341	\$ 37,475,035	\$ 322,694
B. Long Term Water Capital Reserve	\$ 5,725,000	\$ 5,757,010	\$ 32,010
C. Principal Account	\$ 1,175,500	\$ 1,176,300	\$ 800
D. Interest Account	\$ 20,323	\$ 21,671	\$ 1,349
E. O+M Account	\$ 8,988,314	\$ 10,503,185	\$ 1,514,872
F. Current Construction Obligation and Customer Construction Escrows	\$ 70,149	\$ 70,149	\$ -
TOTAL SUMMARY CASH + RESERVE ANALYSIS	\$ 53,131,626	\$ 55,003,351	\$ 1,871,724

TABLE 2	
OTHER CASH	
G. General Fund	\$ 10,433,327
H. Sales Tax	\$ 7,108,383
TOTAL TABLE 2-OTHER CASH	\$ 17,541,711
TOTAL MONTH END FUNDS CASH BALANCE-Table1+2	\$ 72,545,061

Outstanding
Balance
5/31/14

TABLE 3--DEBT	
H. REVENUE BOND FINAL PAYMENT MAY-2016	\$ 24,885,050
I. NORTHERN TRUST BANK-NEXT PAYMENT OF \$7M DUE MAY-2016	\$ 7,000,000

\$ 24,885,050
 \$ 7,000,000

Note 1: The O&M Account target varies from month to month. The cash balance should be enough to cover the current months operating cash outflows, but not exceed \$25 million in balance.

DATE: June 4, 2014

REQUEST FOR BOARD ACTION

AGENDA SECTION Finance Committee	ORIGINATING DEPARTMENT Finance
ITEM Authorize to suspend the Purchasing Procedures of the Commission's By-Laws and to authorize the upgrade of the Incode accounting system from Tyler Technologies at a cost not to exceed \$50,000.00	APPROVAL 
<p>Account Number: 01-60-6280</p> <p>In order to expand reporting capabilities and enhance user proficiencies by the DuPage Water Commission personnel, Staff is recommending an upgrade to Tyler Technologies v.X Incode accounting software. The DuPage Water Commission currently uses an older version of the Incode software by Tyler Technologies for its accounting and reporting needs. The current version being used was originally implemented in 2005.</p> <p>In conjunction with evaluating the upgrade from Tyler Technologies, the Commission also researched other software programs used by other local governments within DuPage County. Some programs did not match the needs of the Commission, while others were well beyond the scope needed and pricing desired. The current version has been suitable for many areas including payroll, accounts payable and general ledger activities. However, due to the age of the software the reporting module is not able to efficiently produce desired information. With this upgrade the reporting capabilities will become much more advanced and flexible.</p> <p>This request would authorize the purchase for service from Tyler Technologies as the exclusive authorized service provider for the conversion to v.X Incode accounting software.</p> <p>This expense was budgeted in the FY 2014/2015 Annual Management Budget, but Board approval is required due to the sole source supply at a cost in excess of \$20,000. Service is estimated not to exceed an expense of \$50,000.00.</p>	
MOTION: Authorize to suspend the Purchasing Procedures of the Commission's By-Laws and authorize the upgrade of the Incode accounting system from Tyler Technologies at a cost not to exceed \$50,000.00	

DATE: June 5, 2014

REQUEST FOR BOARD ACTION

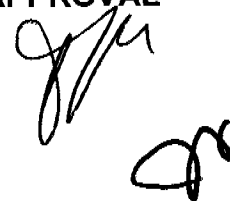
AGENDA SECTION	Engineering & Construction Committee	ORIGINATING DEPARTMENT	General Manager's Office
ITEM	An Ordinance Determining the Prevailing Rate of Wages in DuPage County and Cook County Ordinance No. O-5-14	APPROVAL 	
<p>Attached is "An Ordinance Determining the Prevailing Rate of Wages in DuPage County and Cook County." This Ordinance is adopted annually by the Commission. This Ordinance establishes the prevailing rate of wages for various construction trades working on Commission public works construction projects. The prevailing rate of wages included in this Ordinance have been obtained from the Illinois Department of Labor. The Commission includes a copy of its then current prevailing wage ordinance in all of its public works construction specifications.</p> <p>Once adopted by the Commission, a certified copy of this Ordinance will be filed with both the Secretary of State and the Department of Labor of the State of Illinois as required by law. The Commission will also publish a notice of the adoption of the Ordinance in a newspaper of general circulation within the area, within thirty (30) days following its filing with the Secretary of State and the Department of Labor.</p>			
MOTION: To adopt Ordinance No. O-5-14.			

DUPAGE WATER COMMISSION

ORDINANCE NO. O-5-14

**AN ORDINANCE DETERMINING THE
PREVAILING RATE OF WAGES IN
DUPAGE COUNTY AND COOK COUNTY**

WHEREAS, the State of Illinois has enacted "An Act Regulating Wages of Laborers, Mechanics and Other Workers Employed in Any Public Works by the State, County, City or Any Public Body or Any Political Subdivision or By Anyone Under Contract for Public Works," approved June 26, 1941, as amended, being Act 130 (Prevailing Wage Act), of Chapter 820 (Employment), of the Illinois Compiled Statutes, 820 ILCS 130/0.01 et seq. (the "Act"); and

WHEREAS, the Act requires that the DuPage Water Commission investigate and ascertain the prevailing rate of wages as defined in the Act for laborers, mechanics and other workers in the localities of DuPage County and Cook County employed in the construction of public works for the DuPage Water Commission; and

WHEREAS, "locality" is defined in the Act as the County where the physical work upon public works is performed and the public works of the DuPage Water Commission will be performed in both DuPage and Cook County;

NOW, THEREFORE, BE IT ORDAINED by the Board of Commissioners of the DuPage Water Commission as follows:

SECTION ONE: To the extent and as required by the Act, the general prevailing rate of wages in DuPage County for laborers, mechanics and other workers engaged in the construction of public works coming under the jurisdiction of the DuPage Water Commission, which physical work is being performed on public works in DuPage County, is hereby ascertained to be the same as the prevailing rate of wages for

Ordinance No. O-5-14

construction work in the DuPage County area as determined by the Department of Labor of the State of Illinois as of June 2014. A copy of that determination is attached hereto, and by this reference incorporated herein, as Exhibit A. As required by the Act, any and all revisions of the prevailing rate of wages in DuPage County by the Department of Labor of the State of Illinois shall supersede the Department's June determination and shall apply to any and all public works construction in DuPage County undertaken by the Commission.

SECTION TWO: To the extent and as required by the Act, the general prevailing rate of wages in Cook County for laborers, mechanics and other workers engaged in the construction of public works coming under the jurisdiction of the DuPage Water Commission, which physical work is being performed on public works in Cook County, is hereby ascertained to be the same as the prevailing rate of wages for construction work in the Cook County area as determined by the Department of Labor of the State of Illinois as of June 2014. A copy of that determination is attached hereto, and by this reference incorporated herein, as Exhibit B. As required by the Act, any and all revisions of the prevailing rate of wages in Cook County by the Department of Labor of the State of Illinois shall supersede the Department's June determination and shall apply to any and all public works construction in Cook County undertaken by the Commission.

SECTION THREE: The definition of any terms appearing in this Ordinance that are also used in the Act shall be the same as in the Act. Nothing herein contained shall be construed to apply the general prevailing rate of wages for DuPage County and for Cook County as herein ascertained to any work or employment except public works

Ordinance No. O-5-14

construction of the DuPage Water Commission conducted in DuPage County and Cook County, respectively, to the extent required by the Act.

SECTION FOUR: The Clerk of the DuPage Water Commission shall publicly post or keep available for inspection by any interested party in the main office of the DuPage Water Commission this determination of the prevailing rate of wages for DuPage County and for Cook County.

SECTION FIVE: The General Manager is hereby directed to:

- (a) promptly file, no later than July 18, 2014, a certified copy of this Ordinance with both the Secretary of State and the Department of Labor of the State of Illinois;
- (b) cause to be published in a newspaper of general circulation within the area a notice of the adoption of this Ordinance, within thirty (30) days of its filing with the Secretary of State and the Department of Labor of the State of Illinois, and such publication shall constitute notice that the determination is effective and that this is the determination of this public body;
- (c) mail a copy of this determination to any employer, to any association of employers and to any person or association of employees who have filed their names and addresses, requesting copies of any determination stating the particular rates and the particular class of workers whose wages will be affected by such rate; and
- (d) attach a copy of this determination or of the revised determination of prevailing rate of wages then in effect to all public works construction contract specifications.

Ordinance No. O-5-14

SECTION SIX: This Ordinance shall be in full force and effect from and after its adoption.

AYES:

NAYS:

ABSENT:

ADOPTED this _____ day of _____, 2014.

Chairman

ATTEST:

Clerk

Board/Ordinances/O-5-14.docx

EXHIBIT A

Du Page County Prevailing Wage for May 2014

(See explanation of column headings at bottom of wages)

Trade Name	RG	TYP	C	Base	FRMAN	M-F>8	OSA	OSH	H/W	Pensn	Vac	Trng
ASBESTOS ABT-GEN		ALL		37.100	37.600	1.5	1.5	2.0	13.38	9.520	0.000	0.500
ASBESTOS ABT-MEC		BLD		35.100	37.600	1.5	1.5	2.0	11.17	10.76	0.000	0.720
BOILERMAKER		BLD		44.240	48.220	2.0	2.0	2.0	6.970	17.54	0.000	0.350
BRICK MASON		BLD		41.580	45.740	1.5	1.5	2.0	9.700	12.80	0.000	1.040
CARPENTER		ALL		42.520	44.520	1.5	1.5	2.0	13.29	12.75	0.000	0.630
CEMENT MASON		ALL		38.500	40.500	2.0	1.5	2.0	12.16	16.25	0.000	0.430
CERAMIC TILE FNSHER		BLD		34.810	0.000	2.0	1.5	2.0	10.20	7.830	0.000	0.640
COMMUNICATION TECH		BLD		32.650	34.750	1.5	1.5	2.0	9.550	15.16	1.250	0.610
ELECTRIC PWR EQMT OP		ALL		36.610	49.750	1.5	1.5	2.0	5.000	11.35	0.000	0.270
ELECTRIC PWR GRNDMAN		ALL		28.310	49.750	1.5	1.5	2.0	5.000	8.780	0.000	0.210
ELECTRIC PWR LINEMAN		ALL		43.830	49.750	1.5	1.5	2.0	5.000	13.58	0.000	0.330
ELECTRIC PWR TRK DRV		ALL		29.310	49.750	1.5	1.5	2.0	5.000	9.090	0.000	0.220
ELECTRICIAN		BLD		37.160	40.880	1.5	1.5	2.0	9.550	17.39	4.480	0.680
ELEVATOR CONSTRUCTOR		BLD		49.900	56.140	2.0	2.0	2.0	12.73	13.46	3.990	0.600
FENCE ERECTOR	NE	ALL		34.840	36.840	1.5	1.5	2.0	12.86	10.67	0.000	0.300
FENCE ERECTOR	W	ALL		45.060	48.660	2.0	2.0	2.0	9.390	17.69	0.000	0.400
GLAZIER		BLD		40.000	41.500	1.5	2.0	2.0	12.49	15.99	0.000	0.940
HT/FROST INSULATOR		BLD		46.950	49.450	1.5	1.5	2.0	11.17	11.96	0.000	0.720
IRON WORKER	E	ALL		42.070	44.070	2.0	2.0	2.0	13.45	19.59	0.000	0.350
IRON WORKER	W	ALL		45.060	48.660	2.0	2.0	2.0	9.390	17.69	0.000	0.400
LABORER		ALL		37.000	37.750	1.5	1.5	2.0	13.38	9.520	0.000	0.500
LATHER		ALL		42.520	44.520	1.5	1.5	2.0	13.29	12.75	0.000	0.630
MACHINIST		BLD		43.920	46.420	1.5	1.5	2.0	6.760	8.950	1.850	0.000
MARBLE FINISHERS		ALL		30.520	0.000	1.5	1.5	2.0	9.700	12.55	0.000	0.590
MARBLE MASON		BLD		40.780	44.860	1.5	1.5	2.0	9.700	12.71	0.000	0.740
MATERIAL TESTER I		ALL		27.000	0.000	1.5	1.5	2.0	13.38	9.520	0.000	0.500
MATERIALS TESTER II		ALL		32.000	0.000	1.5	1.5	2.0	13.38	9.520	0.000	0.500
MILLWRIGHT		ALL		42.520	44.520	1.5	1.5	2.0	13.29	12.75	0.000	0.630
OPERATING ENGINEER		BLD	1	46.100	50.100	2.0	2.0	2.0	16.60	11.05	1.900	1.250
OPERATING ENGINEER		BLD	2	44.800	50.100	2.0	2.0	2.0	16.60	11.05	1.900	1.250
OPERATING ENGINEER		BLD	3	42.250	50.100	2.0	2.0	2.0	16.60	11.05	1.900	1.250
OPERATING ENGINEER		BLD	4	40.500	50.100	2.0	2.0	2.0	16.60	11.05	1.900	1.250
OPERATING ENGINEER		BLD	5	49.850	50.100	2.0	2.0	2.0	16.60	11.05	1.900	1.250
OPERATING ENGINEER		BLD	6	47.100	50.100	2.0	2.0	2.0	16.60	11.05	1.900	1.250
OPERATING ENGINEER		BLD	7	49.100	50.100	2.0	2.0	2.0	16.60	11.05	1.900	1.250
OPERATING ENGINEER		HWY	1	44.300	48.300	1.5	1.5	2.0	16.60	11.05	1.900	1.250
OPERATING ENGINEER		HWY	2	43.750	48.300	1.5	1.5	2.0	16.60	11.05	1.900	1.250
OPERATING ENGINEER		HWY	3	41.700	48.300	1.5	1.5	2.0	16.60	11.05	1.900	1.250
OPERATING ENGINEER		HWY	4	40.300	48.300	1.5	1.5	2.0	16.60	11.05	1.900	1.250
OPERATING ENGINEER		HWY	5	39.100	48.300	1.5	1.5	2.0	16.60	11.05	1.900	1.250
OPERATING ENGINEER		HWY	6	47.300	48.300	1.5	1.5	2.0	16.60	11.05	1.900	1.250
OPERATING ENGINEER		HWY	7	45.300	48.300	1.5	1.5	2.0	16.60	11.05	1.900	1.250
ORNAMNTL IRON WORKER E		ALL		42.900	45.400	2.0	2.0	2.0	13.11	16.40	0.000	0.600
ORNAMNTL IRON WORKER W		ALL		45.060	48.660	2.0	2.0	2.0	9.390	17.69	0.000	0.400
PAINTER		ALL		40.980	42.980	1.5	1.5	1.5	10.00	8.200	0.000	1.350
PAINTER SIGNS		BLD		33.920	38.090	1.5	1.5	1.5	2.600	2.710	0.000	0.000
PILEDRIVER		ALL		42.520	44.520	1.5	1.5	2.0	13.29	12.75	0.000	0.630
PIPEFITTER		BLD		41.200	43.200	1.5	1.5	2.0	9.750	17.59	0.000	1.710

PLASTERER	BLD	41.250	43.760	1.5	1.5	2.0	9.700	13.08	0.000	0.980
PLUMBER	BLD	41.200	43.200	1.5	1.5	2.0	9.750	17.59	0.000	1.710
ROOFER	BLD	39.200	42.200	1.5	1.5	2.0	8.280	9.690	0.000	0.430
SHEETMETAL WORKER	BLD	43.250	45.250	1.5	1.5	2.0	10.65	12.90	0.000	0.820
SPRINKLER FITTER	BLD	49.200	51.200	1.5	1.5	2.0	10.75	8.850	0.000	0.450
STEEL ERECTOR	E ALL	42.070	44.070	2.0	2.0	2.0	13.45	19.59	0.000	0.350
STEEL ERECTOR	W ALL	45.060	48.660	2.0	2.0	2.0	9.390	17.69	0.000	0.400
STONE MASON	BLD	41.580	45.740	1.5	1.5	2.0	9.700	12.80	0.000	1.040
SURVEY WORKER	ALL	37.000	37.750	1.5	1.5	2.0	12.97	9.930	0.000	0.500
TERRAZZO FINISHER	BLD	36.040	0.000	1.5	1.5	2.0	10.20	9.900	0.000	0.540
TERRAZZO MASON	BLD	39.880	42.880	1.5	1.5	2.0	10.20	11.25	0.000	0.700
TILE MASON	BLD	41.840	45.840	2.0	1.5	2.0	10.20	9.560	0.000	0.880
TRAFFIC SAFETY WRKR	HWY	28.250	29.850	1.5	1.5	2.0	4.896	4.175	0.000	0.000
TRUCK DRIVER	ALL 1	32.550	33.100	1.5	1.5	2.0	6.500	4.350	0.000	0.150
TRUCK DRIVER	ALL 2	32.700	33.100	1.5	1.5	2.0	6.500	4.350	0.000	0.150
TRUCK DRIVER	ALL 3	32.900	33.100	1.5	1.5	2.0	6.500	4.350	0.000	0.150
TRUCK DRIVER	ALL 4	33.100	33.100	1.5	1.5	2.0	6.500	4.350	0.000	0.150
TUCKPOINTER	BLD	40.950	41.950	1.5	1.5	2.0	9.700	11.93	0.000	0.630

Legend: RG (Region)

TYP (Trade Type - All, Highway, Building, Floating, Oil & Chip, Rivers)

C (Class)

Base (Base Wage Rate)

FRMAN (Foreman Rate)

M-F>8 (OT required for any hour greater than 8 worked each day, Mon through Fri.)

OSA (Overtime (OT) is required for every hour worked on Saturday)

OSH (Overtime is required for every hour worked on Sunday and Holidays)

H/W (Health & Welfare Insurance)

Pensn (Pension)

Vac (Vacation)

Trng (Training)

Explanations**DUPAGE COUNTY**

IRON WORKERS AND FENCE ERECTOR (WEST) - West of Route 53.

The following list is considered as those days for which holiday rates of wages for work performed apply: New Years Day, Memorial Day, Fourth of July, Labor Day, Thanksgiving Day, Christmas Day and Veterans Day in some classifications/counties. Generally, any of these holidays which fall on a Sunday is celebrated on the following Monday. This then makes work performed on that Monday payable at the appropriate overtime rate for holiday pay. Common practice in a given local may alter certain days of celebration. If in doubt, please check with IDOL.

EXPLANATION OF CLASSES

ASBESTOS - GENERAL - removal of asbestos material/mold and hazardous materials from any place in a building, including mechanical systems where those mechanical systems are to be removed. This includes the removal of asbestos materials/mold and hazardous materials from ductwork or pipes in a building when the building is to be demolished at the time or at some close future date.

ASBESTOS - MECHANICAL - removal of asbestos material from mechanical

systems, such as pipes, ducts, and boilers, where the mechanical systems are to remain.

TRAFFIC SAFETY - work associated with barricades, horses and drums used to reduce lane usage on highway work, the installation and removal of temporary lane markings, and the installation and removal of temporary road signs.

CERAMIC TILE FINISHER

The grouting, cleaning, and polishing of all classes of tile, whether for interior or exterior purposes, all burned, glazed or unglazed products; all composition materials, granite tiles, warning detectable tiles, cement tiles, epoxy composite materials, pavers, glass, mosaics, fiberglass, and all substitute materials, for tile made in tile-like units; all mixtures in tile like form of cement, metals, and other materials that are for and intended for use as a finished floor surface, stair treads, promenade roofs, walks, walls, ceilings, swimming pools, and all other places where tile is to form a finished interior or exterior. The mixing of all setting mortars including but not limited to thin-set mortars, epoxies, wall mud, and any other sand and cement mixtures or adhesives when used in the preparation, installation, repair, or maintenance of tile and/or similar materials. The handling and unloading of all sand, cement, lime, tile, fixtures, equipment, adhesives, or any other materials to be used in the preparation, installation, repair, or maintenance of tile and/or similar materials. Ceramic Tile Finishers shall fill all joints and voids regardless of method on all tile work, particularly and especially after installation of said tile work. Application of any and all protective coverings to all types of tile installations including, but not be limited to, all soap compounds, paper products, tapes, and all polyethylene coverings, plywood, masonite, cardboard, and any new type of products that may be used to protect tile installations, Blastrac equipment, and all floor scarifying equipment used in preparing floors to receive tile. The clean up and removal of all waste and materials. All demolition of existing tile floors and walls to be re-tiled.

COMMUNICATIONS TECHNICIAN

Low voltage installation, maintenance and removal of telecommunication facilities (voice, sound, data and video) including telephone and data inside wire, interconnect, terminal equipment, central offices, PABX, fiber optic cable and equipment, micro waves, V-SAT, bypass, CATV, WAN (wide area networks), LAN (local area networks), and ISDN (integrated system digital network), pulling of wire in raceways, but not the installation of raceways.

MARBLE FINISHER

Loading and unloading trucks, distribution of all materials (all stone, sand, etc.), stocking of floors with material, performing all rigging for heavy work, the handling of all material that may be needed for the installation of such materials, building of scaffolding, polishing if needed, patching, waxing of material if damaged, pointing up, caulking, grouting and cleaning of marble, holding water on diamond or Carborundum blade or saw for setters

cutting, use of tub saw or any other saw needed for preparation of material, drilling of holes for wires that anchor material set by setters, mixing up of molding plaster for installation of material, mixing up thin set for the installation of material, mixing up of sand to cement for the installation of material and such other work as may be required in helping a Marble Setter in the handling of all material in the erection or installation of interior marble, slate, travertine, art marble, serpentine, alberene stone, blue stone, granite and other stones (meaning as to stone any foreign or domestic materials as are specified and used in building interiors and exteriors and customarily known as stone in the trade), carrara, sanionyx, vitrolite and similar opaque glass and the laying of all marble tile, terrazzo tile, slate tile and precast tile, steps, risers treads, base, or any other materials that may be used as substitutes for any of the aforementioned materials and which are used on interior and exterior which are installed in a similar manner.

MATERIAL TESTER I: Hand coring and drilling for testing of materials; field inspection of uncured concrete and asphalt.

MATERIAL TESTER II: Field inspection of welds, structural steel, fireproofing, masonry, soil, facade, reinforcing steel, formwork, cured concrete, and concrete and asphalt batch plants; adjusting proportions of bituminous mixtures.

OPERATING ENGINEER - BUILDING

Class 1. Asphalt Plant; Asphalt Spreader; Autograde; Backhoes with Caisson Attachment; Batch Plant; Benoto (requires Two Engineers); Boiler and Throttle Valve; Caisson Rigs; Central Redi-Mix Plant; Combination Back Hoe Front End-loader Machine; Compressor and Throttle Valve; Concrete Breaker (Truck Mounted); Concrete Conveyor; Concrete Conveyor (Truck Mounted); Concrete Paver Over 27E cu. ft; Concrete Paver 27E cu. ft. and Under; Concrete Placer; Concrete Placing Boom; Concrete Pump (Truck Mounted); Concrete Tower; Cranes, All; Cranes, Hammerhead; Cranes, (GCI and similar Type); Creter Crane; Spider Crane; Crusher, Stone, etc.; Derricks, All; Derricks, Traveling; Formless Curb and Gutter Machine; Grader, Elevating; Grouting Machines; Heavy Duty Self-Propelled Transporter or Prime Mover; Highlift Shovels or Front Endloader 2-1/4 yd. and over; Hoists, Elevators, outside type rack and pinion and similar machines; Hoists, One, Two and Three Drum; Hoists, Two Tugger One Floor; Hydraulic Backhoes; Hydraulic Boom Trucks; Hydro Vac (and similar equipment); Locomotives, All; Motor Patrol; Lubrication Technician; Manipulators; Pile Drivers and Skid Rig; Post Hole Digger; Pre-Stress Machine; Pump Cretes Dual Ram; Pump Cretes: Squeeze Cretes-Screw Type Pumps; Gypsum Bulker and Pump; Raised and Blind Hole Drill; Roto Mill Grinder; Scoops - Tractor Drawn; Slip-Form Paver; Straddle Buggies; Operation of Tie Back Machine; Tournapull; Tractor with Boom and Side Boom; Trenching Machines.

Class 2. Boilers; Broom, All Power Propelled; Bulldozers; Concrete Mixer (Two Bag and Over); Conveyor, Portable; Forklift Trucks; Highlift Shovels or Front Endloaders under 2-1/4 yd.; Hoists, Automatic; Hoists, Inside Elevators; Hoists, Sewer Dragging Machine; Hoists, Tugger Single Drum; Laser Screed; Rock Drill (Self-Propelled); Rock Drill (Truck Mounted); Rollers, All; Steam Generators; Tractors,

All; Tractor Drawn Vibratory Roller; Winch Trucks with "A" Frame.

Class 3. Air Compressor; Combination Small Equipment Operator; Generators; Heaters, Mechanical; Hoists, Inside Elevators (remodeling or renovation work); Hydraulic Power Units (Pile Driving, Extracting, and Drilling); Pumps, over 3" (1 to 3 not to exceed a total of 300 ft.); Low Boys; Pumps, Well Points; Welding Machines (2 through 5); Winches, 4 Small Electric Drill Winches.

Class 4. Bobcats and/or other Skid Steer Loaders; Oilers; and Brick Forklift.

Class 5. Assistant Craft Foreman.

Class 6. Gradall.

Class 7. Mechanics; Welders.

OPERATING ENGINEERS - HIGHWAY CONSTRUCTION

Class 1. Asphalt Plant; Asphalt Heater and Planer Combination; Asphalt Heater Scarfire; Asphalt Spreader; Autograder/GOMACO or other similar type machines: ABG Paver; Backhoes with Caisson Attachment; Ballast Regulator; Belt Loader; Caisson Rigs; Car Dumper; Central Redi-Mix Plant; Combination Backhoe Front Endloader Machine, (1 cu. yd. Backhoe Bucket or over or with attachments); Concrete Breaker (Truck Mounted); Concrete Conveyor; Concrete Paver over 27E cu. ft.; Concrete Placer; Concrete Tube Float; Cranes, all attachments; Cranes, Tower Cranes of all types: Creter Crane; Spider Crane; Crusher, Stone, etc.; Derricks, All; Derrick Boats; Derricks, Traveling; Dredges; Elevators, Outside type Rack & Pinion and Similar Machines; Formless Curb and Gutter Machine; Grader, Elevating; Grader, Motor Grader, Motor Patrol, Auto Patrol, Form Grader, Pull Grader, Subgrader; Guard Rail Post Driver Truck Mounted; Hoists, One, Two and Three Drum; Heavy Duty Self-Propelled Transporter or Prime Mover; Hydraulic Backhoes; Backhoes with shear attachments up to 40' of boom reach; Lubrication Technician; Manipulators; Mucking Machine; Pile Drivers and Skid Rig; Pre-Stress Machine; Pump Cretes Dual Ram; Rock Drill - Crawler or Skid Rig; Rock Drill - Truck Mounted; Rock/Track Tamper; Roto Mill Grinder; Slip-Form Paver; Snow Melters; Soil Test Drill Rig (Truck Mounted); Straddle Buggies; Hydraulic Telescoping Form (Tunnel); Operation of Tieback Machine; Tractor Drawn Belt Loader; Tractor Drawn Belt Loader (with attached pusher - two engineers); Tractor with Boom; Tractaire with Attachments; Traffic Barrier Transfer Machine; Trenching; Truck Mounted Concrete Pump with Boom; Raised or Blind Hole Drills (Tunnel Shaft); Underground Boring and/or Mining Machines 5 ft. in diameter and over tunnel, etc; Underground Boring and/or Mining Machines under 5 ft. in diameter; Wheel Excavator; Widener (APSCO).

Class 2. Batch Plant; Bituminous Mixer; Boiler and Throttle Valve; Bulldozers; Car Loader Trailing Conveyors; Combination Backhoe Front Endloader Machine (Less than 1 cu. yd. Backhoe Bucket or over or with attachments); Compressor and Throttle Valve; Compressor, Common Receiver (3); Concrete Breaker or Hydro Hammer; Concrete Grinding Machine; Concrete Mixer or Paver 7S Series to and including 27 cu. ft.; Concrete Spreader; Concrete Curing Machine, Burlap Machine,

Belting Machine and Sealing Machine; Concrete Wheel Saw; Conveyor Muck Cars (Haglund or Similar Type); Drills, All; Finishing Machine - Concrete; Highlift Shovels or Front Endloader; Hoist - Sewer Dragging Machine; Hydraulic Boom Trucks (All Attachments); Hydro-Blaster; Hydro Excavating (excluding hose work); Laser Screed; All Locomotives, Dinky; Off-Road Hauling Units (including articulating) Non Self-Loading Ejection Dump; Pump Cretes: Squeeze Cretes - Screw Type Pumps, Gypsum Bulker and Pump; Roller, Asphalt; Rotary Snow Plows; Rototiller, Seaman, etc., self-propelled; Self-Propelled Compactor; Spreader - Chip - Stone, etc.; Scraper - Single/Twin Engine/Push and Pull; Scraper - Prime Mover in Tandem (Regardless of Size); Tractors pulling attachments, Sheeps Foot, Disc, Compactor, etc.; Tug Boats.

Class 3. Boilers; Brooms, All Power Propelled; Cement Supply Tender; Compressor, Common Receiver (2); Concrete Mixer (Two Bag and Over); Conveyor, Portable; Farm-Type Tractors Used for Mowing, Seeding, etc.; Forklift Trucks; Grouting Machine; Hoists, Automatic; Hoists, All Elevators; Hoists, Tugger Single Drum; Jeep Diggers; Low Boys; Pipe Jacking Machines; Post-Hole Digger; Power Saw, Concrete Power Driven; Pug Mills; Rollers, other than Asphalt; Seed and Straw Blower; Steam Generators; Stump Machine; Winch Trucks with "A" Frame; Work Boats; Tamper-Form-Motor Driven.

Class 4. Air Compressor; Combination - Small Equipment Operator; Directional Boring Machine; Generators; Heaters, Mechanical; Hydraulic Power Unit (Pile Driving, Extracting, or Drilling); Light Plants, All (1 through 5); Pumps, over 3" (1 to 3 not to exceed a total of 300 ft.); Pumps, Well Points; Vacuum Trucks (excluding hose work); Welding Machines (2 through 5); Winches, 4 Small Electric Drill Winches.

Class 5. SkidSteer Loader (all); Brick Forklifts; Oilers.

Class 6. Field Mechanics and Field Welders

Class 7. Dowell Machine with Air Compressor; Gradall and machines of like nature.

SURVEY WORKER - Operated survey equipment including data collectors, G.P.S. and robotic instruments, as well as conventional levels and transits.

TRUCK DRIVER - BUILDING, HEAVY AND HIGHWAY CONSTRUCTION

Class 1. Two or three Axle Trucks. A-frame Truck when used for transportation purposes; Air Compressors and Welding Machines, including those pulled by cars, pick-up trucks and tractors; Ambulances; Batch Gate Lockers; Batch Hopperman; Car and Truck Washers; Carry-alls; Fork Lifts and Hoisters; Helpers; Mechanics Helpers and Greasers; Oil Distributors 2-man operation; Pavement Breakers; Pole Trailer, up to 40 feet; Power Mower Tractors; Self-propelled Chip Spreader; Skipman; Slurry Trucks, 2-man operation; Slurry Truck Conveyor Operation, 2 or 3 man; Teamsters; Unskilled Dumpman; and Truck Drivers hauling warning lights, barricades, and portable toilets on the job site.

Class 2. Four axle trucks; Dump Crets and Adgetors under 7 yards; Dumpsters, Track Trucks, Euclids, Hug Bottom Dump Turnapulls or

Turnatrailers when pulling other than self-loading equipment or similar equipment under 16 cubic yards; Mixer Trucks under 7 yards; Ready-mix Plant Hopper Operator, and Winch Trucks, 2 Axles.

Class 3. Five axle trucks; Dump Crets and Adgetors 7 yards and over; Dumpsters, Track Trucks, Euclids, Hug Bottom Dump Turnatrailers or turnapulls when pulling other than self-loading equipment or similar equipment over 16 cubic yards; Explosives and/or Fission Material Trucks; Mixer Trucks 7 yards or over; Mobile Cranes while in transit; Oil Distributors, 1-man operation; Pole Trailer, over 40 feet; Pole and Expandable Trailers hauling material over 50 feet long; Slurry trucks, 1-man operation; Winch trucks, 3 axles or more; Mechanic--Truck Welder and Truck Painter.

Class 4. Six axle trucks; Dual-purpose vehicles, such as mounted crane trucks with hoist and accessories; Foreman; Master Mechanic; Self-loading equipment like P.B. and trucks with scoops on the front.

TERRAZZO FINISHER

The handling of sand, cement, marble chips, and all other materials that may be used by the Mosaic Terrazzo Mechanic, and the mixing, grinding, grouting, cleaning and sealing of all Marble, Mosaic, and Terrazzo work, floors, base, stairs, and wainscoting by hand or machine, and in addition, assisting and aiding Marble, Masonic, and Terrazzo Mechanics.

Other Classifications of Work:

For definitions of classifications not otherwise set out, the Department generally has on file such definitions which are available. If a task to be performed is not subject to one of the classifications of pay set out, the Department will upon being contacted state which neighboring county has such a classification and provide such rate, such rate being deemed to exist by reference in this document. If no neighboring county rate applies to the task, the Department shall undertake a special determination, such special determination being then deemed to have existed under this determination. If a project requires these, or any classification not listed, please contact IDOL at 217-782-1710 for wage rates or clarifications.

LANDSCAPING

Landscaping work falls under the existing classifications for laborer, operating engineer and truck driver. The work performed by landscape plantsman and landscape laborer is covered by the existing classification of laborer. The work performed by landscape operators (regardless of equipment used or its size) is covered by the classifications of operating engineer. The work performed by landscape truck drivers (regardless of size of truck driven) is covered by the classifications of truck driver.

MATERIAL TESTER & MATERIAL TESTER/INSPECTOR I AND II

Notwithstanding the difference in the classification title, the classification entitled "Material Tester I" involves the same job duties as the classification entitled "Material Tester/Inspector I". Likewise, the classification entitled "Material Tester II" involves the same job duties as the classification entitled "Material Tester/Inspector II".

EXHIBIT B

Cook County Prevailing Wage for May 2014

(See explanation of column headings at bottom of wages)

Trade Name	RG	TYP	C	Base	FRMAN	M-F>8	OSA	OSH	H/W	Pensn	Vac	Trng
ASBESTOS ABT-GEN		ALL		37.100	37.600	1.5	1.5	2.0	13.38	9.520	0.000	0.500
ASBESTOS ABT-MEC		BLD		35.100	37.600	1.5	1.5	2.0	11.17	10.76	0.000	0.720
BOILERMAKER		BLD		44.240	48.220	2.0	2.0	2.0	6.970	17.54	0.000	0.350
BRICK MASON		BLD		41.580	45.740	1.5	1.5	2.0	9.700	12.80	0.000	1.040
CARPENTER		ALL		42.520	44.520	1.5	1.5	2.0	13.29	12.75	0.000	0.630
CEMENT MASON		ALL		42.350	44.350	2.0	1.5	2.0	12.16	12.35	0.000	0.430
CERAMIC TILE FNSHER		BLD		34.810	0.000	2.0	1.5	2.0	10.20	7.830	0.000	0.640
COMM. ELECT.		BLD		38.000	40.800	1.5	1.5	2.0	8.420	11.30	1.100	0.700
ELECTRIC PWR EQMT OP		ALL		44.850	49.850	1.5	1.5	2.0	10.63	14.23	0.000	0.450
ELECTRIC PWR GRNDMAN		ALL		34.980	49.850	1.5	1.5	2.0	8.290	11.10	0.000	0.350
ELECTRIC PWR LINEMAN		ALL		44.850	49.850	1.5	1.5	2.0	10.63	14.23	0.000	0.450
ELECTRICIAN		ALL		43.000	46.000	1.5	1.5	2.0	12.83	14.27	0.000	0.750
ELEVATOR CONSTRUCTOR		BLD		49.900	56.140	2.0	2.0	2.0	12.73	13.46	3.990	0.600
FENCE ERECTOR		ALL		34.840	36.840	1.5	1.5	2.0	12.86	10.67	0.000	0.300
GLAZIER		BLD		40.000	41.500	1.5	2.0	2.0	12.49	15.99	0.000	0.940
HT/FROST INSULATOR		BLD		46.950	49.450	1.5	1.5	2.0	11.17	11.96	0.000	0.720
IRON WORKER		ALL		42.070	44.070	2.0	2.0	2.0	13.45	19.59	0.000	0.350
LABORER		ALL		37.000	37.750	1.5	1.5	2.0	13.38	9.520	0.000	0.500
LATHER		ALL		42.520	44.520	1.5	1.5	2.0	13.29	12.75	0.000	0.630
MACHINIST		BLD		43.920	46.420	1.5	1.5	2.0	6.760	8.950	1.850	0.000
MARBLE FINISHERS		ALL		30.520	0.000	1.5	1.5	2.0	9.700	12.55	0.000	0.590
MARBLE MASON		BLD		40.780	44.860	1.5	1.5	2.0	9.700	12.71	0.000	0.740
MATERIAL TESTER I		ALL		27.000	0.000	1.5	1.5	2.0	13.38	9.520	0.000	0.500
MATERIALS TESTER II		ALL		32.000	0.000	1.5	1.5	2.0	13.38	9.520	0.000	0.500
MILLWRIGHT		ALL		42.520	44.520	1.5	1.5	2.0	13.29	12.75	0.000	0.630
OPERATING ENGINEER		BLD	1	46.100	50.100	2.0	2.0	2.0	16.60	11.05	1.900	1.250
OPERATING ENGINEER		BLD	2	44.800	50.100	2.0	2.0	2.0	16.60	11.05	1.900	1.250
OPERATING ENGINEER		BLD	3	42.250	50.100	2.0	2.0	2.0	16.60	11.05	1.900	1.250
OPERATING ENGINEER		BLD	4	40.500	50.100	2.0	2.0	2.0	16.60	11.05	1.900	1.250
OPERATING ENGINEER		BLD	5	49.850	50.100	2.0	2.0	2.0	16.60	11.05	1.900	1.250
OPERATING ENGINEER		BLD	6	47.100	50.100	2.0	2.0	2.0	16.60	11.05	1.900	1.250
OPERATING ENGINEER		BLD	7	49.100	50.100	2.0	2.0	2.0	16.60	11.05	1.900	1.250
OPERATING ENGINEER		FLT	1	51.300	51.300	1.5	1.5	2.0	15.70	10.55	1.900	1.250
OPERATING ENGINEER		FLT	2	49.800	51.300	1.5	1.5	2.0	15.70	10.55	1.900	1.250
OPERATING ENGINEER		FLT	3	44.350	51.300	1.5	1.5	2.0	15.70	10.55	1.900	1.250
OPERATING ENGINEER		FLT	4	36.850	51.300	1.5	1.5	2.0	15.70	10.55	1.900	1.250
OPERATING ENGINEER		FLT	5	52.800	51.300	1.5	1.5	2.0	15.70	10.55	1.900	1.250
OPERATING ENGINEER		HWY	1	44.300	48.300	1.5	1.5	2.0	16.60	11.05	1.900	1.250
OPERATING ENGINEER		HWY	2	43.750	48.300	1.5	1.5	2.0	16.60	11.05	1.900	1.250
OPERATING ENGINEER		HWY	3	41.700	48.300	1.5	1.5	2.0	16.60	11.05	1.900	1.250
OPERATING ENGINEER		HWY	4	40.300	48.300	1.5	1.5	2.0	16.60	11.05	1.900	1.250
OPERATING ENGINEER		HWY	5	39.100	48.300	1.5	1.5	2.0	16.60	11.05	1.900	1.250
OPERATING ENGINEER		HWY	6	47.300	48.300	1.5	1.5	2.0	16.60	11.05	1.900	1.250
OPERATING ENGINEER		HWY	7	45.300	48.300	1.5	1.5	2.0	16.60	11.05	1.900	1.250
ORNAMNTL IRON WORKER		ALL		42.900	45.400	2.0	2.0	2.0	13.11	16.40	0.000	0.600
PAINTER		ALL		40.750	45.500	1.5	1.5	1.5	10.75	11.10	0.000	0.770
PAINTER SIGNS		BLD		33.920	38.090	1.5	1.5	1.5	2.600	2.710	0.000	0.000
PILEDRIIVER		ALL		42.520	44.520	1.5	1.5	2.0	13.29	12.75	0.000	0.630

PIPEFITTER	BLD	46.000	49.000	1.5	1.5	2.0	9.000	15.85	0.000	1.680
PLASTERER	BLD	41.250	43.730	1.5	1.5	2.0	11.10	11.69	0.000	0.550
PLUMBER	BLD	46.050	48.050	1.5	1.5	2.0	12.53	10.06	0.000	0.880
ROOFER	BLD	39.200	42.200	1.5	1.5	2.0	8.280	9.690	0.000	0.430
SHEETMETAL WORKER	BLD	41.210	44.510	1.5	1.5	2.0	10.48	19.41	0.000	0.660
SIGN HANGER	BLD	30.210	30.710	1.5	1.5	2.0	4.850	3.030	0.000	0.000
SPRINKLER FITTER	BLD	49.200	51.200	1.5	1.5	2.0	10.75	8.850	0.000	0.450
STEEL ERECTOR	ALL	42.070	44.070	2.0	2.0	2.0	13.45	19.59	0.000	0.350
STONE MASON	BLD	41.580	45.740	1.5	1.5	2.0	9.700	12.80	0.000	1.040
SURVEY WORKER	ALL	37.000	37.750	1.5	1.5	2.0	12.97	9.930	0.000	0.500
TERRAZZO FINISHER	BLD	36.040	0.000	1.5	1.5	2.0	10.20	9.900	0.000	0.540
TERRAZZO MASON	BLD	39.880	42.880	1.5	1.5	2.0	10.20	11.25	0.000	0.700
TILE MASON	BLD	41.840	45.840	2.0	1.5	2.0	10.20	9.560	0.000	0.880
TRAFFIC SAFETY WRKR	HWY	28.250	29.850	1.5	1.5	2.0	4.896	4.175	0.000	0.000
TRUCK DRIVER	E ALL 1	33.850	34.500	1.5	1.5	2.0	8.150	8.500	0.000	0.150
TRUCK DRIVER	E ALL 2	34.100	34.500	1.5	1.5	2.0	8.150	8.500	0.000	0.150
TRUCK DRIVER	E ALL 3	34.300	34.500	1.5	1.5	2.0	8.150	8.500	0.000	0.150
TRUCK DRIVER	E ALL 4	34.500	34.500	1.5	1.5	2.0	8.150	8.500	0.000	0.150
TRUCK DRIVER	W ALL 1	32.550	33.100	1.5	1.5	2.0	6.500	4.350	0.000	0.000
TRUCK DRIVER	W ALL 2	32.700	33.100	1.5	1.5	2.0	6.500	4.350	0.000	0.000
TRUCK DRIVER	W ALL 3	32.900	33.100	1.5	1.5	2.0	6.500	4.350	0.000	0.000
TRUCK DRIVER	W ALL 4	33.100	33.100	1.5	1.5	2.0	6.500	4.350	0.000	0.000
TUCKPOINTER	BLD	41.950	42.950	1.5	1.5	2.0	8.180	11.78	0.000	0.630

Legend: RG (Region)

TYP (Trade Type - All, Highway, Building, Floating, Oil & Chip, Rivers)

C (Class)

Base (Base Wage Rate)

FRMAN (Foreman Rate)

M-F>8 (OT required for any hour greater than 8 worked each day, Mon through Fri.)

OSA (Overtime (OT) is required for every hour worked on Saturday)

OSH (Overtime is required for every hour worked on Sunday and Holidays)

H/W (Health & Welfare Insurance)

Pensn (Pension)

Vac (Vacation)

Trng (Training)

Explanations**COOK COUNTY**

The following list is considered as those days for which holiday rates of wages for work performed apply: New Years Day, Memorial Day, Fourth of July, Labor Day, Thanksgiving Day, Christmas Day and Veterans Day in some classifications/counties. Generally, any of these holidays which fall on a Sunday is celebrated on the following Monday. This then makes work performed on that Monday payable at the appropriate overtime rate for holiday pay. Common practice in a given local may alter certain days of celebration. If in doubt, please check with IDOL.

TRUCK DRIVERS (WEST) - That part of the county West of Barrington Road.

EXPLANATION OF CLASSES

ASBESTOS - GENERAL - removal of asbestos material/mold and hazardous materials from any place in a building, including mechanical systems

where those mechanical systems are to be removed. This includes the removal of asbestos materials/mold and hazardous materials from ductwork or pipes in a building when the building is to be demolished at the time or at some close future date.

ASBESTOS - MECHANICAL - removal of asbestos material from mechanical systems, such as pipes, ducts, and boilers, where the mechanical systems are to remain.

CERAMIC TILE FINISHER

The grouting, cleaning, and polishing of all classes of tile, whether for interior or exterior purposes, all burned, glazed or unglazed products; all composition materials, granite tiles, warning detectable tiles, cement tiles, epoxy composite materials, pavers, glass, mosaics, fiberglass, and all substitute materials, for tile made in tile-like units; all mixtures in tile like form of cement, metals, and other materials that are for and intended for use as a finished floor surface, stair treads, promenade roofs, walks, walls, ceilings, swimming pools, and all other places where tile is to form a finished interior or exterior. The mixing of all setting mortars including but not limited to thin-set mortars, epoxies, wall mud, and any other sand and cement mixtures or adhesives when used in the preparation, installation, repair, or maintenance of tile and/or similar materials. The handling and unloading of all sand, cement, lime, tile, fixtures, equipment, adhesives, or any other materials to be used in the preparation, installation, repair, or maintenance of tile and/or similar materials. Ceramic Tile Finishers shall fill all joints and voids regardless of method on all tile work, particularly and especially after installation of said tile work. Application of any and all protective coverings to all types of tile installations including, but not be limited to, all soap compounds, paper products, tapes, and all polyethylene coverings, plywood, masonite, cardboard, and any new type of products that may be used to protect tile installations, Blastrac equipment, and all floor scarifying equipment used in preparing floors to receive tile. The clean up and removal of all waste and materials. All demolition of existing tile floors and walls to be re-tiled.

COMMUNICATIONS ELECTRICIAN

Installation, operation, inspection, maintenance, repair and service of radio, television, recording, voice sound vision production and reproduction, telephone and telephone interconnect, facsimile, data apparatus, coaxial, fibre optic and wireless equipment, appliances and systems used for the transmission and reception of signals of any nature, business, domestic, commercial, education, entertainment, and residential purposes, including but not limited to, communication and telephone, electronic and sound equipment, fibre optic and data communication systems, and the performance of any task directly related to such installation or service whether at new or existing sites, such tasks to include the placing of wire and cable and electrical power conduit or other raceway work within the equipment room and pulling wire and/or cable through conduit and the installation of any incidental conduit, such that the employees covered hereby can complete any job in full.

MARBLE FINISHER

Loading and unloading trucks, distribution of all materials (all stone, sand, etc.), stocking of floors with material, performing all rigging for heavy work, the handling of all material that may be needed for the installation of such materials, building of scaffolding, polishing if needed, patching, waxing of material if damaged, pointing up, caulking, grouting and cleaning of marble, holding water on diamond or Carborundum blade or saw for setters cutting, use of tub saw or any other saw needed for preparation of material, drilling of holes for wires that anchor material set by setters, mixing up of molding plaster for installation of material, mixing up thin set for the installation of material, mixing up of sand to cement for the installation of material and such other work as may be required in helping a Marble Setter in the handling of all material in the erection or installation of interior marble, slate, travertine, art marble, serpentine, alberene stone, blue stone, granite and other stones (meaning as to stone any foreign or domestic materials as are specified and used in building interiors and exteriors and customarily known as stone in the trade), carrara, sanionyx, vitrolite and similar opaque glass and the laying of all marble tile, terrazzo tile, slate tile and precast tile, steps, risers treads, base, or any other materials that may be used as substitutes for any of the aforementioned materials and which are used on interior and exterior which are installed in a similar manner.

MATERIAL TESTER I: Hand coring and drilling for testing of materials; field inspection of uncured concrete and asphalt.

MATERIAL TESTER II: Field inspection of welds, structural steel, fireproofing, masonry, soil, facade, reinforcing steel, formwork, cured concrete, and concrete and asphalt batch plants; adjusting proportions of bituminous mixtures.

OPERATING ENGINEER - BUILDING

Class 1. Asphalt Plant; Asphalt Spreader; Autograde; Backhoes with Caisson Attachment; Batch Plant; Benoto (requires Two Engineers); Boiler and Throttle Valve; Caisson Rigs; Central Redi-Mix Plant; Combination Back Hoe Front End-loader Machine; Compressor and Throttle Valve; Concrete Breaker (Truck Mounted); Concrete Conveyor; Concrete Conveyor (Truck Mounted); Concrete Paver Over 27E cu. ft; Concrete Paver 27E cu. ft. and Under; Concrete Placer; Concrete Placing Boom; Concrete Pump (Truck Mounted); Concrete Tower; Cranes, All; Cranes, Hammerhead; Cranes, (GCI and similar Type); Creter Crane; Spider Crane; Crusher, Stone, etc.; Derricks, All; Derricks, Traveling; Formless Curb and Gutter Machine; Grader, Elevating; Grouting Machines; Heavy Duty Self-Propelled Transporter or Prime Mover; Highlift Shovels or Front Endloader 2-1/4 yd. and over; Hoists, Elevators, outside type rack and pinion and similar machines; Hoists, One, Two and Three Drum; Hoists, Two Tugger One Floor; Hydraulic Backhoes; Hydraulic Boom Trucks; Hydro Vac (and similar equipment); Locomotives, All; Motor Patrol; Lubrication Technician; Manipulators; Pile Drivers and Skid Rig; Post Hole Digger; Pre-Stress Machine; Pump Cretes Dual Ram; Pump Cretes: Squeeze Cretes-Screw Type Pumps; Gypsum Bulker and Pump; Raised and Blind Hole Drill; Roto Mill Grinder; Scoops - Tractor Drawn; Slip-Form Paver; Straddle Buggies; Operation

of Tie Back Machine; Tournapull; Tractor with Boom and Side Boom; Trenching Machines.

Class 2. Boilers; Broom, All Power Propelled; Bulldozers; Concrete Mixer (Two Bag and Over); Conveyor, Portable; Forklift Trucks; Highlift Shovels or Front Endloaders under 2-1/4 yd.; Hoists, Automatic; Hoists, Inside Elevators; Hoists, Sewer Dragging Machine; Hoists, Tugger Single Drum; Laser Screed; Rock Drill (Self-Propelled); Rock Drill (Truck Mounted); Rollers, All; Steam Generators; Tractors, All; Tractor Drawn Vibratory Roller; Winch Trucks with "A" Frame.

Class 3. Air Compressor; Combination Small Equipment Operator; Generators; Heaters, Mechanical; Hoists, Inside Elevators (remodeling or renovation work); Hydraulic Power Units (Pile Driving, Extracting, and Drilling); Pumps, over 3" (1 to 3 not to exceed a total of 300 ft.); Low Boys; Pumps, Well Points; Welding Machines (2 through 5); Winches, 4 Small Electric Drill Winches.

Class 4. Bobcats and/or other Skid Steer Loaders; Oilers; and Brick Forklift.

Class 5. Assistant Craft Foreman.

Class 6. Gradall.

Class 7. Mechanics; Welders.

OPERATING ENGINEERS - HIGHWAY CONSTRUCTION

Class 1. Asphalt Plant; Asphalt Heater and Planer Combination; Asphalt Heater Scarfire; Asphalt Spreader; Autograder/GOMACO or other similar type machines: ABG Paver; Backhoes with Caisson Attachment; Ballast Regulator; Belt Loader; Caisson Rigs; Car Dumper; Central Redi-Mix Plant; Combination Backhoe Front Endloader Machine, (1 cu. yd. Backhoe Bucket or over or with attachments); Concrete Breaker (Truck Mounted); Concrete Conveyor; Concrete Paver over 27E cu. ft.; Concrete Placer; Concrete Tube Float; Cranes, all attachments; Cranes, Tower Cranes of all types: Creter Crane: Spider Crane; Crusher, Stone, etc.; Derricks, All; Derrick Boats; Derricks, Traveling; Dredges; Elevators, Outside type Rack & Pinion and Similar Machines; Formless Curb and Gutter Machine; Grader, Elevating; Grader, Motor Grader, Motor Patrol, Auto Patrol, Form Grader, Pull Grader, Subgrader; Guard Rail Post Driver Truck Mounted; Hoists, One, Two and Three Drum; Heavy Duty Self-Propelled Transporter or Prime Mover; Hydraulic Backhoes; Backhoes with shear attachments up to 40' of boom reach; Lubrication Technician; Manipulators; Mucking Machine; Pile Drivers and Skid Rig; Pre-Stress Machine; Pump Cretes Dual Ram; Rock Drill - Crawler or Skid Rig; Rock Drill - Truck Mounted; Rock/Track Tamper; Roto Mill Grinder; Slip-Form Paver; Snow Melters; Soil Test Drill Rig (Truck Mounted); Straddle Buggies; Hydraulic Telescoping Form (Tunnel); Operation of Tieback Machine; Tractor Drawn Belt Loader; Tractor Drawn Belt Loader (with attached pusher - two engineers); Tractor with Boom; Tractaire with Attachments; Traffic Barrier Transfer Machine; Trenching; Truck Mounted Concrete Pump with Boom; Raised or Blind Hole Drills (Tunnel Shaft); Underground Boring and/or Mining Machines 5 ft. in diameter and over tunnel, etc; Underground Boring and/or Mining

Machines under 5 ft. in diameter; Wheel Excavator; Widener (APSCO).

Class 2. Batch Plant; Bituminous Mixer; Boiler and Throttle Valve; Bulldozers; Car Loader Trailing Conveyors; Combination Backhoe Front Endloader Machine (Less than 1 cu. yd. Backhoe Bucket or over or with attachments); Compressor and Throttle Valve; Compressor, Common Receiver (3); Concrete Breaker or Hydro Hammer; Concrete Grinding Machine; Concrete Mixer or Paver 7S Series to and including 27 cu. ft.; Concrete Spreader; Concrete Curing Machine, Burlap Machine, Belting Machine and Sealing Machine; Concrete Wheel Saw; Conveyor Muck Cars (Haglund or Similar Type); Drills, All; Finishing Machine - Concrete; Highlift Shovels or Front Endloader; Hoist - Sewer Dragging Machine; Hydraulic Boom Trucks (All Attachments); Hydro-Blaster; Hydro Excavating (excluding hose work); Laser Screed; All Locomotives, Dinky; Off-Road Hauling Units (including articulating) Non Self-Loading Ejection Dump; Pump Cretes: Squeeze Cretes - Screw Type Pumps, Gypsum Bulker and Pump; Roller, Asphalt; Rotary Snow Plows; Rototiller, Seaman, etc., self-propelled; Self-Propelled Compactor; Spreader - Chip - Stone, etc.; Scraper - Single/Twin Engine/Push and Pull; Scraper - Prime Mover in Tandem (Regardless of Size); Tractors pulling attachments, Sheeps Foot, Disc, Compactor, etc.; Tug Boats.

Class 3. Boilers; Brooms, All Power Propelled; Cement Supply Tender; Compressor, Common Receiver (2); Concrete Mixer (Two Bag and Over); Conveyor, Portable; Farm-Type Tractors Used for Mowing, Seeding, etc.; Forklift Trucks; Grouting Machine; Hoists, Automatic; Hoists, All Elevators; Hoists, Tugger Single Drum; Jeep Diggers; Low Boys; Pipe Jacking Machines; Post-Hole Digger; Power Saw, Concrete Power Driven; Pug Mills; Rollers, other than Asphalt; Seed and Straw Blower; Steam Generators; Stump Machine; Winch Trucks with "A" Frame; Work Boats; Tamper-Form-Motor Driven.

Class 4. Air Compressor; Combination - Small Equipment Operator; Directional Boring Machine; Generators; Heaters, Mechanical; Hydraulic Power Unit (Pile Driving, Extracting, or Drilling); Light Plants, All (1 through 5); Pumps, over 3" (1 to 3 not to exceed a total of 300 ft.); Pumps, Well Points; Vacuum Trucks (excluding hose work); Welding Machines (2 through 5); Winches, 4 Small Electric Drill Winches.

Class 5. SkidSteer Loader (all); Brick Forklifts; Oilers.

Class 6. Field Mechanics and Field Welders

Class 7. Dowell Machine with Air Compressor; Gradall and machines of like nature.

OPERATING ENGINEER - FLOATING

Class 1. Craft Foreman; Master Mechanic; Diver/Wet Tender; Engineer; Engineer (Hydraulic Dredge).

Class 2. Crane/Backhoe Operator; Boat Operator with towing endorsement; Mechanic/Welder; Assistant Engineer (Hydraulic Dredge); Leverman (Hydraulic Dredge); Diver Tender.

Class 3. Deck Equipment Operator, Machineryman, Maintenance of Crane (over 50 ton capacity) or Backhoe (115,000 lbs. or more); Tug/Launch

Operator; Loader/Dozer and like equipment on Barge, Breakwater Wall, Slip/Dock, or Scow, Deck Machinery, etc.

Class 4. Deck Equipment Operator, Machineryman/Fireman (4 Equipment Units or More); Off Road Trucks; Deck Hand, Tug Engineer, Crane Maintenance (50 Ton Capacity and Under) or Backhoe Weighing (115,000 pounds or less); Assistant Tug Operator.

Class 5. Friction or Lattice Boom Cranes.

SURVEY WORKER - Operated survey equipment including data collectors, G.P.S. and robotic instruments, as well as conventional levels and transits.

TERRAZZO FINISHER

The handling of sand, cement, marble chips, and all other materials that may be used by the Mosaic Terrazzo Mechanic, and the mixing, grinding, grouting, cleaning and sealing of all Marble, Mosaic, and Terrazzo work, floors, base, stairs, and wainscoting by hand or machine, and in addition, assisting and aiding Marble, Masonic, and Terrazzo Mechanics.

TRAFFIC SAFETY

Work associated with barricades, horses and drums used to reduce lane usage on highway work, the installation and removal of temporary lane markings, and the installation and removal of temporary road signs.

TRUCK DRIVER - BUILDING, HEAVY AND HIGHWAY CONSTRUCTION - EAST & WEST

Class 1. Two or three Axle Trucks. A-frame Truck when used for transportation purposes; Air Compressors and Welding Machines, including those pulled by cars, pick-up trucks and tractors; Ambulances; Batch Gate Lockers; Batch Hopperman; Car and Truck Washers; Carry-alls; Fork Lifts and Hoisters; Helpers; Mechanics Helpers and Greasers; Oil Distributors 2-man operation; Pavement Breakers; Pole Trailer, up to 40 feet; Power Mower Tractors; Self-propelled Chip Spreader; Skipman; Slurry Trucks, 2-man operation; Slurry Truck Conveyor Operation, 2 or 3 man; Teamsters; Unskilled Dumpman; and Truck Drivers hauling warning lights, barricades, and portable toilets on the job site.

Class 2. Four axle trucks; Dump Crets and Adgetors under 7 yards; Dumpsters, Track Trucks, Euclids, Hug Bottom Dump Turnapulls or Turnatrailers when pulling other than self-loading equipment or similar equipment under 16 cubic yards; Mixer Trucks under 7 yards; Ready-mix Plant Hopper Operator, and Winch Trucks, 2 Axles.

Class 3. Five axle trucks; Dump Crets and Adgetors 7 yards and over; Dumpsters, Track Trucks, Euclids, Hug Bottom Dump Turnatrailers or turnapulls when pulling other than self-loading equipment or similar equipment over 16 cubic yards; Explosives and/or Fission Material Trucks; Mixer Trucks 7 yards or over; Mobile Cranes while in transit; Oil Distributors, 1-man operation; Pole Trailer, over 40 feet; Pole and Expandable Trailers hauling material over 50 feet long; Slurry trucks, 1-man operation; Winch trucks, 3 axles or more;

Mechanic--Truck Welder and Truck Painter.

Class 4. Six axle trucks; Dual-purpose vehicles, such as mounted crane trucks with hoist and accessories; Foreman; Master Mechanic; Self-loading equipment like P.B. and trucks with scoops on the front.

Other Classifications of Work:

For definitions of classifications not otherwise set out, the Department generally has on file such definitions which are available. If a task to be performed is not subject to one of the classifications of pay set out, the Department will upon being contacted state which neighboring county has such a classification and provide such rate, such rate being deemed to exist by reference in this document. If no neighboring county rate applies to the task, the Department shall undertake a special determination, such special determination being then deemed to have existed under this determination. If a project requires these, or any classification not listed, please contact IDOL at 217-782-1710 for wage rates or clarifications.

LANDSCAPING



Landscaping work falls under the existing classifications for laborer, operating engineer and truck driver. The work performed by landscape plantsman and landscape laborer is covered by the existing classification of laborer. The work performed by landscape operators (regardless of equipment used or its size) is covered by the classifications of operating engineer. The work performed by landscape truck drivers (regardless of size of truck driven) is covered by the classifications of truck driver.

MATERIAL TESTER & MATERIAL TESTER/INSPECTOR I AND II

Notwithstanding the difference in the classification title, the classification entitled "Material Tester I" involves the same job duties as the classification entitled "Material Tester/Inspector I". Likewise, the classification entitled "Material Tester II" involves the same job duties as the classification entitled "Material Tester/Inspector II".

DATE: June 6, 2014

REQUEST FOR BOARD ACTION

AGENDA SECTION Engineering & Construction Committee	ORIGINATING DEPARTMENT Instrumentation/ Remote Facilities
ITEM A Resolution Approving and Ratifying Certain Work Authorization Orders Under Quick Response Electrical Contract QRE-6/12 at the June 19, 2014, DuPage Water Commission Meeting Resolution No. R-15-14	APPROVAL   
<p>Account Numbers: 01-60-6633</p> <p>The Commission entered into certain agreements dated December 10, 2012, with Divane Bros. Electric Co. and with McWilliams Electric Co. Inc. for quick response electrical work as needed through the issuance of Work Authorization Orders. Resolution No. R-15-14 would approve the following Work Authorization Order under the Quick Response Electrical Contracts:</p> <p>Work Authorization Order No. 010: This Work Authorization was issued to Divane Bros. Electric Co., and the work completed, prior to board approval and was in response to the loss of power do to the service entrance pulled away from the ComEd transformer by a Village of Bellwood's grass mower. The Commission is in contact with the Village of Bellwood's Public Works Superintendent for possible reimbursement of repairs.</p> <p>The total cost for this work is \$1,112.75.</p>	
MOTION: To adopt Resolution No. R-15-14.	

DuPAGE WATER COMMISSION

RESOLUTION NO. R-15-14

A RESOLUTION APPROVING AND RATIFYING
CERTAIN WORK AUTHORIZATION ORDERS
UNDER QUICK RESPONSE ELECTRICAL CONTRACT QRE-6/12
AT THE JUNE 19, 2014, DuPAGE WATER COMMISSION MEETING

WHEREAS, the DuPage Water Commission (the "Commission") entered into certain agreements dated December 10, 2012, with Divane Bros. Electric Co. and with McWilliams Electric Co. Inc. for quick response electrical work related to the Commission's Waterworks System (said agreements being hereinafter collectively referred to as "Contract QRE-6/12"); and

WHEREAS, Contract QRE-6/12 is designed to allow the Commission to direct one or more or all of the quick response electrical contractors to perform emergency electrical work, including without limitation electrical work that the Commission is unable to perform through its own personnel and with its own equipment, as needed through the issuance of Work Authorization Orders; and

WHEREAS, the need for such emergency electrical work could not have been reasonably foreseen at the time the contracts were signed;

NOW, THEREFORE, BE IT RESOLVED by the Board of Commissioners of the DuPage Water Commission as follows:

SECTION ONE: The foregoing recitals are by this reference incorporated herein and made a part hereof as findings of the Board of Commissioners of the DuPage Water Commission.

SECTION TWO: The Work Authorization Orders attached hereto and by this reference incorporated herein and made a part hereof as Exhibit 1 shall be and hereby

Resolution No. R-15-14

are approved and, if already issued, ratified because the Board of Commissioners of the DuPage Water Commission has determined, based upon the representations of staff, that the circumstances said to necessitate the Work Authorization Orders were not reasonably foreseeable at the time the contracts were signed, the Work Authorization Orders are germane to the original contracts as signed, and/or the Work Authorization Orders are in the best interest of the DuPage Water Commission and authorized by law.

SECTION THREE: This Resolution shall constitute the written determination required by Section 33E-9 of the Criminal Code of 1961 and shall be in full force and effect from and after its adoption.

AYES:

NAYS:

ABSENT:

ADOPTED this ____ day of _____, 2014

Chairman

ATTEST:

Clerk

Exhibit 1

WORK AUTHORIZATION ORDER

SHEET 1 OF 2

CONTRACT QRE-6/12: QUICK RESPONSE ELECTRICAL CONTRACT

PROJECT: QRE-6.010

LOCATION:

ROV40A, Prairie Path in Bellwood just East of Mannheim Rd near Warren Ave.

CONTRACTOR:

Divane Bros. Electric Co.

DESCRIPTION OF WORK:

Remove and replace damaged 1" RGC conduit and reuse existing cable if not found to be defective through megger testing. Secure new conduit to power pole and seal top of conduit and new conduit coupling underground. Leave at least 2' of cable hanging out at top of conduit for ComEd to splice to from transformer.

REASON FOR WORK:

It appears that Bellwood's grass mowers snagged the conduit riser on the power pole and pulled it down, which pulled the cables out of the splice connections at the transformer on the pole. The Commission is in contact with the Village of Bellwood's Public Works Superintendent for possible reimbursement of repairs.

MINIMUM RESPONSE TIME:

None

COMMISSION-SUPPLIED MATERIALS, EQUIPMENT AND SUPPLIES TO BE INCORPORATED INTO THE WORK:

None

THE WORK ORDERED PURSUANT TO THIS WORK AUTHORIZATION ORDER

IS IS NOT PRIORITY EMERGENCY WORK

SUBMITTALS REQUESTED:

None

SUPPLEMENTARY NOTIFICATION OF POTENTIALLY HAZARDOUS CONDITIONS:

None

SUPPLEMENTARY CONTRACT SPECIFICATIONS AND DRAWINGS:

None

DUPAGE WATER COMMISSION

By: 
Signature of Authorized Representative

DATE: 5-8-14

CONTRACTOR RECEIPT ACKNOWLEDGED:

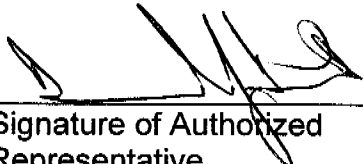
By: 
Signature of Authorized Representative
Daniel J. Divane, IV - President

DATE: May 13, 2014

REQUEST FOR BOARD ACTION

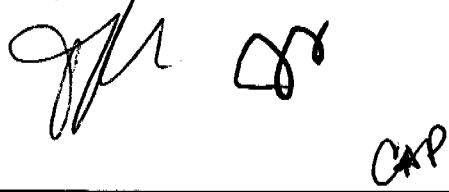
AGENDA SECTION	Engineering & Construction Committee	ORIGINATING DEPARTMENT	Operations
ITEM	<p>A Resolution Approving and Ratifying Certain Task Orders Under a Master Contract with AECOM</p> <p>Resolution No. R-16-14</p>	<p>APPROVAL</p> 	
<p>Account No.: 01-60-7712 - \$250,000 (Estimated)</p>			
<p>The Commission entered into Master Contracts with several firms for professional engineering services. Staff requested proposals from eight (8) of the firms to provide Professional Services for Condition Assessment of Commission Facilities and Underground Assets under the Commission Fiscal Year 2014/2015 Capital Budget.</p>			
<p>Seven (7) proposals were received and Staff selected four (4) firms for in-person interviews. (AECOM, Baxter & Woodman, Greeley & Hansen, and HDR). Staff evaluated each firm on the following criteria: Project Team, Current Experience, Project Methodology, and Price.</p>			
<p>At the conclusion of the interview process staff ranked the firms and deemed the most favorable proposal for the Commission is AECOM</p>			
<p>Under this Task Order AECOM will develop a guidance manual that will be utilized in the completion of a baseline condition assessment and identifying any deficiencies as well as developing both a short and long term Capital Program.</p>			
<p>MOTION: To adopt Resolution No. R-16-14.</p>			

DuPAGE WATER COMMISSION

RESOLUTION NO. R-16-14

A RESOLUTION APPROVING AND RATIFYING CERTAIN
TASK ORDERS UNDER A MASTER CONTRACT
WITH AECOM AT THE
JUNE 19, 2014, DuPAGE WATER COMMISSION MEETING

WHEREAS, the DuPage Water Commission (the "Commission") entered into a contract with AECOM (the "Consultant") to provide, from time to time, professional engineering services in connection with various projects of the Commission (the "Master Contract"); and

WHEREAS, the Master Contract sets forth the terms and conditions pursuant to which the Commission will obtain from time to time, and the Consultant will provide from time to time, professional engineering services for such discrete projects as are delineated and described in Task Orders to be approved by the Commission and the Consultant; and

WHEREAS, the Consultant has approved the Task Orders attached hereto and by this reference incorporated herein and made a part hereof as Exhibit 1 (the "Task Orders");

NOW, THEREFORE, BE IT RESOLVED by the Board of Commissioners of the DuPage Water Commission as follows:

SECTION ONE: The foregoing recitals are incorporated herein and made a part hereof as findings of the Board of Commissioners of the DuPage Water Commission.

SECTION TWO: The Task Orders attached hereto as Exhibit 1 shall be and hereby are approved and, if already issued, ratified because the Board of Commissioners of the DuPage Water Commission has determined, based upon the representations of staff and the Consultant, that the circumstances said to necessitate the Task Orders were

Resolution No. R-16-14

not reasonably foreseeable at the time the Master Contract was signed, the Task Orders are germane to the Master Contract as signed, and/or the Task Orders are in the best interest of the DuPage Water Commission and authorized by law.

SECTION THREE: This Resolution shall constitute the written determination required by Section 33E-9 of Article 33E of the Criminal Code of 1961 and shall be in full force and effect from and after its adoption.

AYES:

NAYS:

ABSENT:

ADOPTED THIS _____ DAY OF _____, 2014.

Chairman

ATTEST:

Clerk

EXHIBIT 1

TASK ORDER #3

In accordance with Section 1.1 of the Master Contract between the DuPage Water Commission and AECOM, ("Consultant"), for Professional Engineering Services dated June 19, 2013 (the "Contract"), Owner and Consultant agree as follows:

1. **Project:**

Under this Task Order condition assessment reports will be prepared for each of the following DWC facilities:

DWC campus located at 600 E. Butterfield Rd. Elmhurst, IL

25% of the DWC (81) Metering Stations (selected by DWC)

25% of the DWC (33) Remotely Operated Valve (selected by DWC)

5% of the DWC (202) Miles of Pipeline (selected by DWC)

10% of the DWC (626) Distribution System Valves (selected by DWC)

4 Standpipe Locations located on the western border of DuPage County

2. **Services of Consultant:**

Perform multi discipline condition assessment field investigations of facilities and buried assets (see Project Description) and prepare condition assessment report

Identify improvement needs and construction and project costs

Provide draft report for review

Conduct workshop to review draft report

Incorporate comments and provide draft final report

Schedule and facilitate periodic coordination meetings held by DWC staff

3. **Approvals and Authorizations:** Consultant shall obtain the following approvals and authorizations:

None.

4. **Commencement Date:**

June 20, 2014

5. **Completion Date:**

April 30, 2015

6. **Submittal Schedule:**

- TBD

7. **Key Project Personnel:**

To Be Determined.

8. **Contract Price:**

\$250,000.00 except as adjusted by a Change Order issued pursuant to Section 2.1 of the Contract.

9. **Payments:**

For purposes of payments to Consultant, the value of the Services under this Task Order shall be determined as follows:

To Be Determined

10. **Modifications to Contract:**

As may be established by the General Manager of Owner and confirmed by an authorized officer of Consultant in writing.

11. **Attachments:**

None.

Approval and Acceptance: Acceptance and approval of this Task Order, including the attachments listed above, shall incorporate this Task Order as part of the Contract.

The Effective Date of this Task Order is June 20, 2014.

DUPAGE WATER COMMISSION

By: _____
John Spatz
General Manager

DESIGNATED REPRESENTATIVE FOR TASK ORDER:

Name: Terry McGhee

Title: Manager of Operations

Address: 600 East Butterfield Road, Elmhurst, Illinois 60126-4642

E-mail Address: mcghee@dpwc.org

Phone: (630) 834-0100

Fax: (630) 834-0120

AECOM

By: _____

Name: _____

Title: _____

DESIGNATED REPRESENTATIVE FOR TASK ORDER:

Name:

Title:

Address:

E-mail Address:

Phone:

Fax:

DATE: June 12, 2014

REQUEST FOR BOARD ACTION

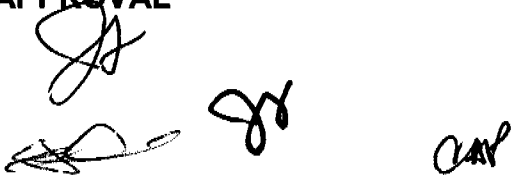
AGENDA SECTION	Engineering & Construction Committee	ORIGINATING DEPARTMENT	Pipeline
ITEM	A Resolution Awarding a Contract to Furnish and Deliver Manhole Frames and Lids. Resolution No. R-17-14	APPROVAL	

Account No.: 01-60-6637

At the April 17, 2014, Commission meeting, the Board approved a Management Budget for Fiscal Year 2014-2015 which included the purchase of 2 different types of manhole frames and lids in the aggregate budgeted amount of \$49,100.00.

In accordance with the Purchasing Procedures of Article VIII Section 4 of the Commission's By-Laws, and as required by state statute, the Commission solicited proposals to Furnish and Deliver Manhole Frames and Lids. Proposals were solicited by direct invitation letters to the foundries listed in the table below, and by posting notice on the Commission's website. Sealed proposals were received until 1:00 p.m., local time, Tuesday May 27, 2014, at which time the proposal of Neenah Foundry Company, the sole proposal received, was publicly opened and read aloud. The proposal contained no omissions, the unit prices were consistent with prior purchases, and previous supplies furnished to the Commission from Neenah Foundry Company have been delivered in a timely fashion and without material defect. Therefore staff is recommending awarding a contract to Furnish and Deliver Manhole Frames and Lids to Neenah Foundry Company.

Neenah Foundry Company	\$37,800.00
Barry Pattern and Foundry Company	No bid
Vestal Manufacturing	No bid
Baas & Hays Foundry	No bid
Signicast	No bid

Approval of Resolution No. R-17-14 would award a Contract to Furnish and Deliver Manhole Frames and Lids to Neenah Foundry Company for the unit prices set forth in its Contract/Proposal, initially amounting to \$37,800.00.

MOTION: To adopt Resolution No. R-17-14.

DUPAGE WATER COMMISSION

RESOLUTION NO. R-17-14

A RESOLUTION AWARDING A CONTRACT TO FURNISH AND DELIVER MANHOLE
FRAMES AND LIDS

WHEREAS, pursuant to Article VIII, Section 4 of the Commission's By-Laws, and as required by State statute, the Commission solicited sealed proposals to Furnish and Deliver Manhole Frames and Lids; and

WHEREAS, one sealed proposal to Furnish and Deliver Manhole Frames and Lids were received on May 27, 2014; and

WHEREAS, pursuant to Article VIII, Section 4 of the Commission's By-Laws, in cases where only one bid is received, the awarding of a contract must be approved by the Board of Commissioners; and

WHEREAS, based upon staff's review of the proposals received, the Board of Commissioners of the DuPage Water Commission has determined that the proposal of Neenah Foundry Company was the most favorable to the interests of the Commission;

NOW, THEREFORE, BE IT RESOLVED by the Board of Commissioners of the DuPage Water Commission as follows:

SECTION ONE: The foregoing recitals are incorporated herein as findings of the DuPage Water Commission.

SECTION TWO: The DuPage Water Commission hereby awards the Contract to Furnish and Deliver Manhole Frames and Lids to Neenah Foundry Company for the unit prices set forth in Its Contract/Proposal, initially amounting to \$37,800.00, conditioned upon the receipt of all contractually required documentation and such other additional information that may be requested by the General Manager of the Commission in

Resolution No. R-17-14

accordance with the Request for Proposals document that is acceptable to the DuPage Water Commission.

SECTION THREE: This Resolution shall be in full force and effect from and after its adoption.

AYES:

NAYS:

ABSENT:

ADOPTED THIS ___ DAY OF _____, 2014.

Chairman

ATTEST:

Clerk

Board/Resolutions/2014/R-17-14.docx

Exhibit A

DUPAGE WATER COMMISSION

CONTRACT/PROPOSAL

FURNISH AND DELIVER MANHOLE FRAMES AND LIDS

Full Name of Bidder NEENAH FOUNDRY ("Bidder")
Principal Office Address 3121 BROOKS AVE. NEENAH W.I. 54956
Local Office Address 545 KIMBERLY AVE. CAROL STREAM, FL. 60188
Contact Person PAT TUMPANE Telephone Number 630-653-5440

TO: DuPage Water Commission ("Owner")
600 East Butterfield Road
Elmhurst, Illinois 60126-4642
Attention: John F. Spatz, Jr.
General Manager

Bidder warrants and represents that Bidder has carefully reviewed and understood all documents included, referred to, or mentioned in this bound set of documents, including Addenda Nos. NONE [if none, write "NONE"], which are securely stapled to the end of this Contract/Proposal.

1. Work Proposal

A. Contract and Work. If this Contract/Proposal is accepted, Bidder proposes, and agrees, that Bidder shall, at its sole cost and expense, provide, perform, and complete, in the manner specified and described, and upon the terms and conditions set forth, in this Contract/Proposal and Owner's written notification of acceptance in the form included in this bound set of documents, all of the following, all of which is herein referred to as the "Work":

1. Labor, Equipment, Materials and Supplies. Provide, perform, and complete, in the manner specified and described in this Contract/Proposal, all necessary work, labor, services, transportation, equipment, materials, supplies, information, data, and other means and items necessary for Furnish and Deliver Manhole Frames and Lids.;
2. Permits. Procure and furnish all permits, licenses, and other governmental approvals and authorizations necessary in connection therewith;
3. Insurance. Procure all insurance specified in this Contract/Proposal;
4. Taxes. Pay all applicable federal, state, and local taxes;
5. Miscellaneous. Do all other things required of Bidder by this Contract/Proposal; and
6. Quality. Provide, perform, and complete all of the foregoing in a proper and workmanlike manner, consistent with highest standards of professional and construction practices, in full compliance with, and as required by or pursuant to, this Contract/Proposal, and with the greatest economy, efficiency, and expedition consistent

therewith, with only new, undamaged, and first quality equipment, materials, and supplies.

B. Performance Standards. If this Contract/Proposal is accepted, Bidder proposes, and agrees, that all Work shall be fully provided, performed, and completed in accordance with the specifications attached hereto and by this reference made a part of this Contract/Proposal as Attachment A and the drawing attached hereto and by this reference made a part of this Contract/Proposal as Attachment B. Any substitution, alteration, deviation, or variation from the specifications in Attachment A or the drawings in Attachment B will be deemed nonconforming and rejected. No provision of any referenced standard, specification, manual, or code shall change the duties and responsibilities of Owner or Bidder from those set forth in this Contract/Proposal.

C. Responsibility for Damage or Loss. If this Contract/Proposal is accepted, Bidder proposes, and agrees, that Bidder shall be responsible and liable for, and shall promptly and without charge to Owner repair or replace, damage done to, and any loss or injury suffered by, Owner, the Work, or other property or persons as a result of the Work.

D. Inspection/Testing/Rejection. Owner shall have the right to inspect all or any part of the Work and to reject all or any part of the Work that is, in Owner's judgment, defective or damaged or that in any way fails to conform strictly to the requirements of this Contract/Proposal and Owner, without limiting its other rights or remedies, may require correction or replacement at Bidder's cost, perform or have performed all Work necessary to complete or correct all or any part of the Work that is defective, damaged, or nonconforming and charge Bidder with any excess cost incurred thereby, or cancel all or any part of any order or this Contract/Proposal. Work so rejected may be returned or held at Bidder's expense and risk.

2. Contract Price Proposal

If this Contract/Proposal is accepted, Bidder proposes, and agrees, that Bidder shall take in full payment for all Work and other matters set forth under Section 1 above, including overhead and profit; taxes, contributions, and premiums; and compensation to all subcontractors and suppliers, the compensation set forth below.

A. SCHEDULE OF PRICES

For providing, performing, and completing all Work, the sum of the products resulting from multiplying the actual number of acceptable units of Unit Price Items listed in the Schedule of Prices attached hereto as Attachment C delivered to Owner by the Unit Price set forth the Schedule of Prices attached hereto as Attachment C for such Unit Price Item.

B. BASIS FOR DETERMINING PRICES

It is expressly understood and agreed that:

1. All prices stated in the Schedule of Prices are firm and shall not be subject to escalation or change;
2. Owner is not subject to state or local sales, use, and excise taxes, that no such taxes are included in the Schedule of Prices, and that all claim or right to claim any additional compensation by reason of the payment of any such tax is hereby waived and released;
3. All other applicable federal, state, and local taxes of every kind and nature applicable to the Work are included in the Schedule of Prices;
4. The approximate quantities set forth in the Schedule of Prices for each Unit Price Item are Owner's estimate only, that Owner reserves the right to increase or decrease such quantities, that payment for each Unit Price Item shall be made only on the actual number of acceptable units of such Unit Price Item delivered to Owner in full compliance with this Contract/Proposal, and that all claim or right to dispute or complain of any such estimated quantity, or to assert that there was any misunderstanding in regard to the nature or amount of any Unit Price Item to be provided or performed, is hereby waived and released; and
5. Any items of Work not specifically listed or referred to in the Schedule of Prices, or not specifically included for payment under any Unit Price Item, shall be deemed incidental to the Contract Price, shall not be measured for payment, and shall not be paid for separately except as incidental to the Contract Price, including without limitation the cost of transportation, FOB Point of Destination Elmhurst, Illinois, packing, cartage, and containers.

C. VALUE OF WORK

It is expressly understood and agreed that the value of the Work shall be determined as follows:

1. The value of Work shall be determined by Owner on the basis of the actual number of acceptable units of Unit Price Items delivered to Owner multiplied by the applicable Unit Price set forth in the Schedule of Prices attached hereto as Attachment C.
2. The Contract Price shall be adjusted to reflect the actual number of acceptable units of Unit Price

Items delivered to Owner upon final acceptance of the Work by Owner.

D. TIME OF PAYMENT

Owner shall pay to Bidder the value of Work, determined in the manner set forth above, and delivered to Owner. Payment shall be in an amount equal to the sum of the number of acceptable units delivered multiplied by the per unit price and shall be made within sixty (60) days of the delivery and acceptance of the units.

3. Contract Time Proposal

If this Contract/Proposal is accepted, Bidder proposes, and agrees, that Bidder shall commence the Work within 10 days following Owner's acceptance of this Contract/Proposal (the "Commencement Date"). If this Contract/Proposal is accepted, Bidder proposes, and agrees, that Bidder shall perform the Work diligently and continuously and shall complete the Work not later than 90 calendar days following the Commencement Date.

4. Financial Assurance

A. Insurance. If this Contract/Proposal is accepted, Bidder proposes, and agrees, that Bidder will procure and maintain such insurance as will cover and include the entire obligation assumed by Bidder in this Contract/Proposal, as well as public liability insurance, including contractual liability, contractors liability and protective liability, automobile liability insurance, including non-owned automobile liability, and Workmen's Compensation and employer's liability insurance as will adequately protect Owner, the Work, and other property and persons against all damages, liability claims, losses and expenses (including attorney's fees) which may arise, or be alleged to have arisen, out of or in connection with Bidder's performance of, or failure to perform, the Work or any part thereof.

B. Indemnification. If this Contract/Proposal is accepted, Bidder proposes, and agrees, that Bidder shall indemnify, save harmless, and defend Owner against all damages, liability, claims, losses, and expenses (including attorneys' fees) that may arise, or be alleged to have arisen, out of or in connection with Bidder's performance of, or failure to perform, the Work or any part thereof, or any failure to meet the representations and warranties set forth in Section 6 of this Contract/Proposal.

C. Penalties. If this Contract/Proposal is accepted, Bidder proposes, and agrees, that Bidder shall be solely liable for any fines or civil penalties that are imposed by any governmental or quasi-governmental agency or body that may arise, or be alleged to have arisen, out of or in connection with Bidder's performance of, or failure to perform, the Work or any part thereof.

5. Firm Proposal

All prices and other terms stated in this Contract/Proposal are firm and shall not be subject to withdrawal, escalation, or change provided Owner accepts this Contract/Proposal within 60 days after the date this sealed Contract/Proposal is opened.

6. Bidder's Representations and Warranties

In order to induce Owner to accept this Contract/Proposal, Bidder hereby represents and warrants as follows:

A. The Work. The Work, and all of its components, shall be of merchantable quality; shall be free from any latent or patent defects and flaws in workmanship, materials, and design; shall strictly conform to the requirements of this Contract/Proposal, including, without limitation, the performance standards set forth in Section 1B of this Contract/Proposal; and shall be fit, sufficient, and suitable for the purposes expressed in, or reasonably inferred from, this Contract/Proposal and the warranties expressed herein shall be in addition to any other warranties expressed or implied by law, which are hereby reserved unto Owner. Bidder shall, promptly and without charge, correct any failure to fulfill the above warranty at any time within two years after final payment or such longer period as may be prescribed in the performance standards set forth in Section 1B of this Contract/Proposal or by law. The above warranty shall be extended automatically to cover all repaired and replacement parts and labor provided or performed under such warranty and Bidder's obligation to correct Work shall be extended for a period of two years from the date of such repair or replacement. The time period established in this Section 6A relates only to the specific obligation of Bidder to correct Work and shall not be construed to establish a period of limitation with respect to other obligations that Bidder has under this Contract/Proposal.

B. Compliance with Laws. The Work, and all of its components, shall be provided, performed, and completed in compliance with, and Bidder agrees to be bound by, all applicable federal, state, and local laws, orders, rules, and regulations, as they may be modified or amended from time to time, including without limitation any prevailing wage laws; any statutes requiring preference to laborers of specified classes; the Illinois Steel Products Procurement Act, 30 ILCS 565/1 et seq.; any statutes prohibiting discrimination because of, or requiring affirmative action based on, race, creed, color, national origin, age, sex, or other prohibited classification; and any statutes regarding safety or the performance of the Work.

C. Not Barred. Bidder is not barred by law from contracting with Owner or with any other unit of state or local government for any reason, including without limitation as a result of (i) a violation of either Section 33E-3 or Section 33E-4 of Article 33 of the Criminal Code of 1961, 720 ILCS 5/33E-1 et seq.; or (ii) a violation of the USA Patriot Act of 2001, 107 Public Law 56 (October 26, 2001) (the "Patriot Act") or other statutes, orders, rules, and regulations of the United States government and its various executive departments, agencies and offices related to the subject matter of the Patriot Act, including, but not limited to, Executive Order 13224 effective September 24, 2001. Bidder is not acting, directly or indirectly, for or on behalf of any person, group, entity or nation named by the United States Treasury Department as a Specially Designated National and Blocked Person, or for or on behalf of any person, group, entity or nation designated in Presidential Executive Order 13224 as a person who commits, threatens to commit, or supports terrorism; and Bidder is not engaged in this transaction directly or indirectly on behalf of, or facilitating this transaction directly or indirectly on behalf of, any such person, group, entity or nation.

D. Qualified. Bidder has the requisite experience, ability, capital, facilities, plant, organization, and staff to enable Bidder to perform the Work successfully and promptly and to commence and complete the Work within the Contract Price and Contract Time Proposals set forth above.

In submitting this Contract/Proposal, Bidder acknowledges and agrees that:

7. Acknowledgments

A. Reliance. Owner is relying on all warranties, representations, and statements made by Bidder in this Contract/Proposal.

B. Reservation of Rights. Owner reserves the right to reject any and all proposals, reserves the right to reject the low price proposal, and reserves such other rights as are set forth in the Instructions to Bidders.

C. Acceptance. If this Contract/Proposal is accepted, Bidder shall be bound by each and every term, condition, or provision contained in this Contract/Proposal and in Owner's written notification of acceptance in the form included in this bound set of documents.

D. Remedies. Each of the rights and remedies reserved to Owner in this Contract/Proposal shall be cumulative and additional to any other or further remedies provided in law or equity or in this Contract/Proposal.

E. No Waiver. No examination, inspection, investigation, test, measurement, review, determination, decision, certificate, or approval by Owner, whether before or after Owner's acceptance of this Contract/Proposal; nor any information or data supplied by Owner, whether before or after Owner's acceptance of this Contract/Proposal; nor any order by Owner for the payment of money; nor any payment for, or use, possession, or acceptance of, the whole or any part of the Work by Owner; nor any extension of time granted by Owner; nor any delay by Owner in exercising any right under this Contract/Proposal; nor any other act or omission of Owner shall constitute or be deemed to be an acceptance of any defective, damaged, or nonconforming Work, nor operate to waive or otherwise diminish the effect of any representation or warranty made by Bidder; or of any requirement or provision of this Contract/Proposal; or of any remedy, power, or right of Owner.

F. Severability. The provisions of this Contract/Proposal shall be interpreted when possible to sustain their legality and enforceability as a whole. In the event any provision of this Contract/Proposal shall be held invalid, illegal, or unenforceable by a court of competent jurisdiction, in whole or in part, neither the validity of the remaining part of such provision, nor the validity of any other provisions of this Contract/Proposal shall be in any way affected thereby.

G. Amendments. No modification, addition, deletion, revision, alteration, or other change to this Contract/Proposal shall be effective unless and until such change is reduced to writing and executed and delivered by Owner and Bidder.

H. Assignment. Neither this Contract/Proposal, nor any interest herein, shall be assigned or subcontracted, in whole or in part, by Bidder except upon the prior written consent of Owner.

I. Governing Law. This Contract/Proposal and the rights of the parties under this Contract/Proposal shall be interpreted according to the internal laws, but not the conflict of law rules, of the State of Illinois. Every provision of law required by law to be inserted into this Contract/Proposal shall be deemed to be inserted herein.

DATED this 20TH day of MAY 2014

Bidder's Status: () WISCONSIN Corporation () _____ Partnership () Individual Proprietor
(State) (State)

Bidder's Name: NEENAH FOUNDRY

Doing Business As (if different): SAME

Signature of Bidder or Authorized Agent: [Signature]

(corporate seal) Printed Name: SPAT TUMPANE
(if corporation)

Title/Position: REGIONAL SALES DIRECTOR

Bidder's Business Address: 545 KIMBERLY DR.
CAROLSTREAM, IL. 60188

Bidder's Business Telephone: 630-653-5440 Facsimile: 630-653-0170

If a Corporation or Partnership, list all Officers or Partners:

NAME	TITLE	ADDRESS
<u>GOLDEN TREE ASSET MANAGEMENT L.P. (60%)</u>	<u>SHARE HOLDER</u>	<u>300 PARK AVE. 30TH FLOOR NEW YORK, NY 10022</u>
<u>MAC KAY SHIELDS (30%)</u>	<u>SHARE HOLDER</u>	<u>1345 AVE. OF THE AMERICAS NEW YORK, NY 10105</u>

THERE ARE NO OTHER SHARE HOLDERS THAT HAVE MORE THAN 5% OF THE COMPANY

Attachment A

SPECIFICATIONS – Manhole Frames and Lids

If the Contract/Proposal is accepted, Bidder proposes, and agrees, that all Work shall be fully provided, performed, and completed in accordance with the following specifications:

1. Material

- A. Frame and lid materials shall conform to ASTM A-48 35 B for Cast Grey Iron. Fasteners shall be Stainless Steel and Galvanized Steel as detailed on Attachment B. Washers and gaskets shall be Neoprene and Nitrile Rubber and as detailed on Attachment B.

2. Conformance with Drawings

- A. All components of the work shall conform in all respects to the dimensions shown on Attachment B and to those Material Specifications described in 1-A above.

3. Delivery

- A. Bidder shall provide a 48 hour notice to Owner to schedule the delivery of Manhole Frames and Lids FOB Point of Destination to the DuPage Water Commission, 600 East Butterfield Road, Elmhurst, IL. Delivery will only be accepted between the hours of 7:00 a.m. and 3:30 p.m. Monday through Friday excluding holidays.

4. Publicity

- A. Owner's name or insignia, photographs of the Work, or any other publicity pertaining to the Work shall not be used in any magazine, trade paper, newspaper, or other medium without the express written consent of Owner.

Attachment B

Drawings - Manhole Frames and Lids

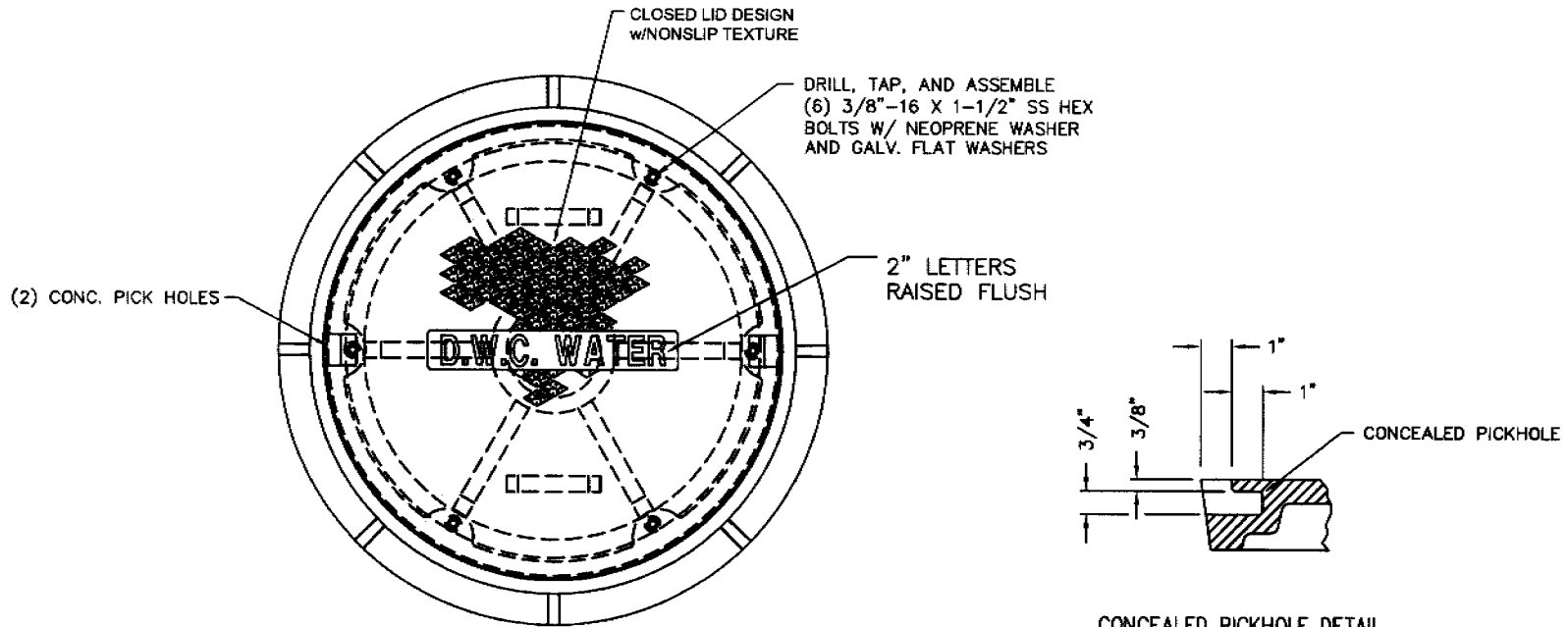

CONCEALED PICKHOLE DETAIL
QUARTER SCALE

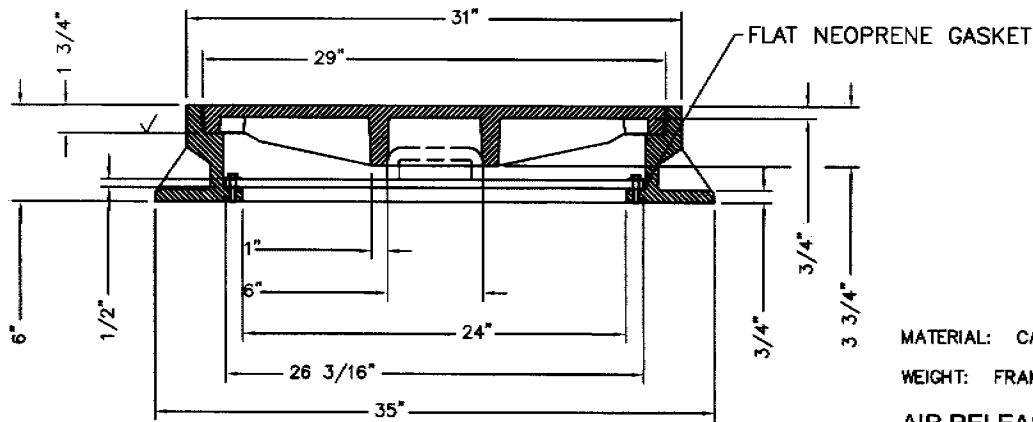

MATERIAL: CAST GRAY IRON ASTM A-48, CLASS 35B

WEIGHT: FRAME 237#, LID 195#, INNER LID 72#

AIR RELEASE FRAME AND LID DETAIL

NOT TO SCALE

Attachment B Drawings – Manhole Frames and Lids

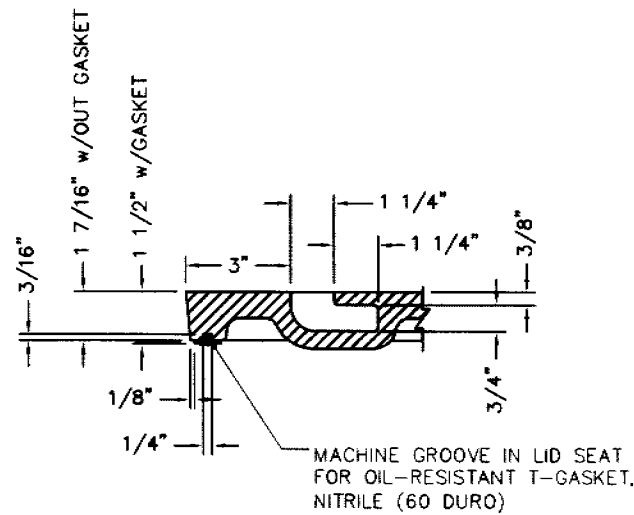
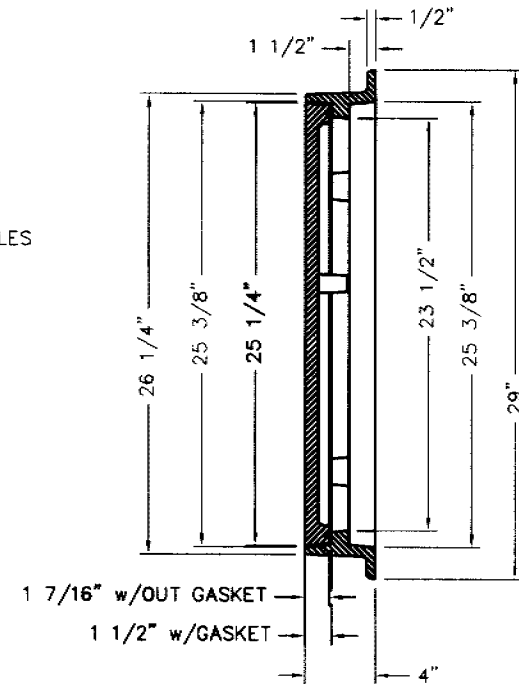
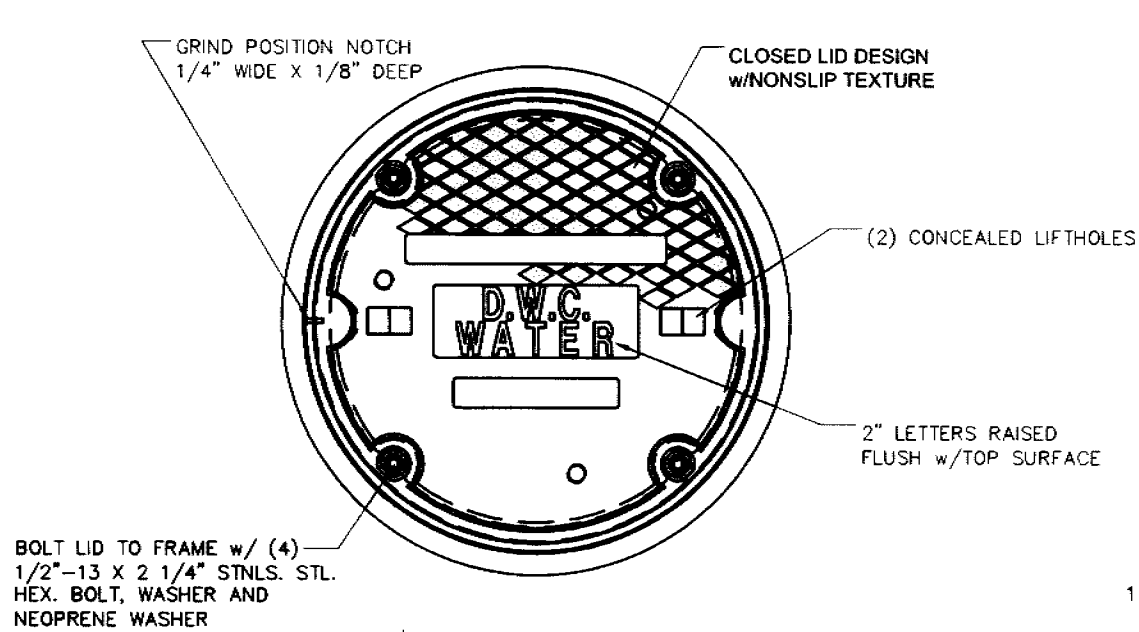

MATERIAL: CAST GRAY IRON ASTM A-48, CLASS 35B

WEIGHT: FRAME-76#, LID-102#

BLOW-OFF FRAME AND LID DETAIL

NOT TO SCALE

Attachment C

SCHEDULE OF PRICES

If the Contract/Proposal is accepted, Bidder proposes, and agrees, that Bidder shall take in full payment for all Work and other matters set forth under Section 1 of the Contract/Proposal, including overhead and profit; taxes, contributions, and premiums; and compensation to all subcontractors and suppliers, the compensation set forth below.

For providing, performing, and completing all Work, the sum of the products resulting from multiplying the actual number of acceptable units of Unit Price Items listed below delivered to Owner by the Unit Price set forth below for such Unit Price Item:

Item No.	Description	Unit	A Cost Per Unit	B Number of Units	C (AxB) Extension
1	Air Release Frame and Lid R-1757-G	Each	\$1,040. ⁰⁰	30	\$31,200.00
2	Blow -Off Frame and Lid R-6462 - FH	Each	\$330. ⁰⁰	20	\$6,600.00

TOTAL OF COLUMNS C ITEMS 1-2 THIRTY ONE THOUSAND TWO HUNDRED Dollars and ZERO Cents
 (in writing) (in writing)

SIX THOUSAND SIX HUNDRED Dollars and ZERO Cents
 (in figures) (in figures)

B. BASIS FOR DETERMINING PRICES

It is expressly understood and agreed that:

- All prices stated in this Schedule of Prices are firm and shall not be subject to escalation or change;
- Owner is not subject to state or local sales, use, and excise taxes, that no such taxes are included in this Schedule of Prices, and that all claim or right to claim any additional compensation by reason of the payment of any such tax is hereby waived and released;
- All other applicable federal, state, and local taxes of every kind and nature applicable to the Work are included in this Schedule of Prices;
- The approximate quantities set forth in this Schedule of Prices for each Unit Price Item are Owner's estimate only, that Owner reserves the right to increase or decrease such quantities, that payment for each Unit Price Item shall be made only on the actual number of acceptable units of such Unit Price Item delivered to Owner in full compliance with the Contract/Proposal, and that all claim or right to dispute or complain of any such estimated quantity, or to assert that there was any misunderstanding in regard to the nature or amount of any Unit Price Item to be provided or performed, is hereby waived and released; and
- Any items of Work not specifically listed or referred to in this Schedule of Prices, or not specifically included for payment under any Unit Price Item, shall be deemed incidental to the Contract Price, shall not be measured for payment, and shall not be paid for separately except as incidental to the Contract Price, including without limitation the cost of transportation, FOB Point of Destination Elmhurst, Illinois, packing, cartage, and containers.

Signature of Bidder or Authorized Agent: Pat Tumpane

Printed Name: PAT TUMPANE

Title/Position: REGIONAL SALES DIRECTOR

ACCEPTANCE

The Contract/Proposal attached hereto and by this reference incorporated herein and made a part hereof is hereby accepted by the order of the DuPage Water Commission ("Owner") this ____ day of _____, 2014

This Acceptance, together with the Contract/Proposal attached hereto, constitutes the entire and only agreement between the parties relating to the accomplishment of the Work and the compensation therefor and supersedes and merges any other prior or contemporaneous discussions, agreements, or understandings, whether written or oral, and shall prevail over any contradictory or inconsistent terms or conditions contained in any purchase order, acceptance, acknowledgement, invoice, or other standard form used by the parties in the performance of the Contract/Proposal. Any such contradictory or inconsistent terms or conditions shall be deemed objected to by Owner without further notice of objection and shall be of no effect nor in any circumstances binding upon Owner unless accepted by Owner in a written document plainly labeled "Amendment to Contract/Proposal." Acceptance or rejection by Owner of any such contradictory or inconsistent terms or conditions shall not constitute acceptance of any other contradictory or inconsistent terms or conditions.

DuPAGE WATER COMMISSION

By: _____
John F. Spatz, Jr.
General Manager

Exhibit B

DuPAGE WATER COMMISSION

REQUEST FOR PROPOSALS

OWNER:

DuPage Water Commission
600 East Butterfield Road
Elmhurst, Illinois 60126-4642

Owner will receive sealed proposals for the Work generally described as follows:

FURNISH AND DELIVER MANHOLE FRAMES AND LIDS

TO BE SUBMITTED TO DuPage Water Commission, 600 East Butterfield Road, Elmhurst, Illinois 60126-4642, Attention John F. Spatz, Jr., General Manager, BEFORE 1:00 P.M., May 27th, 2014.

INSTRUCTIONS TO BIDDERS

Preparation of Proposals

All proposals for the Work shall be made only on the blank Contract/Proposal form attached to this Request for Proposals, FOB Point of Destination Elmhurst, Illinois, and shall be complete with a price for each and every item named in the Schedule of Prices attached to the Contract/Proposal form as Attachment C. All proposals shall be dated on page 4 of the Contract/Proposal form and shall be signed by an authorized official, including page 5 of the Contract/Proposal form and the Schedule of Prices attached to the Contract/Proposal form as Attachment C. Proposals that contain omissions, erasures, alterations, or additions not called for, conditional or alternate bids unless called for, or that contain irregularities of any kind may be rejected.

Clarifications

Owner reserves the right to make clarifications, corrections, or changes in this Request for Proposals at any time prior to the time proposals are opened. All bidders or prospective bidders will be informed of said clarifications, corrections, or changes. If any prospective bidder has questions about this Request for Proposals, contact Ed Kazmierczak, Pipeline Supervisor, at 630-834-0100 between the hours of 7:00 AM and 3:30 PM.

Delivery of Proposals

Each proposal shall be submitted in a sealed envelope plainly marked with the title of the contract and bidder's full legal name and shall be addressed and delivered to the place and before the time set forth above. Proposals may be delivered by mail or in person. Proposals received after the time specified above will be returned unopened.

Opening of Proposals

Proposals will be publicly opened and read at the time and place specified above. Bidders, their authorized agents, and interested parties are invited to be present.

Withdrawal of Proposals

No proposal shall be withdrawn for a period of 60 days after the opening of any proposal.

Rejection of Proposals

Proposals that are not submitted on the Contract/Proposal form or that are not prepared in accordance with these Instructions to Bidders may be rejected. If not rejected, Owner may demand correction of any deficiency and accept the deficiently prepared proposal upon compliance with these Instructions to Bidders.

Acceptance of Proposals

Proposals submitted are offers only and the decision to accept or reject is a function of quality, reliability, capability, reputation, and expertise of the bidders.

Owner reserves the right to accept the proposal that is, in its judgment, the best and most favorable to the interests of Owner and to the public; to reject the low price proposal; to accept any item of any proposal; to reject any and all proposals; and to waive irregularities and informalities in any proposal submitted or in the request for proposal process; provided, however, the waiver of any prior defect or informality shall not be considered a waiver of any future or similar defect or informality. Bidders should not rely upon, or anticipate, such waivers in submitting their proposal.

Upon acceptance of the successful Bidder's proposal by Owner, the successful Bidder's proposal, together with Owner's notification of acceptance in the form attached to this Request for Proposals, shall become the contract for the Work.

DATED this 5th day of May 2014.



DuPAGE WATER COMMISSION

By: /s/ John F. Spatz, Jr.
General Manager

DATE: June 12, 2014

REQUEST FOR BOARD ACTION

AGENDA SECTION	Engineering & Construction Committee	ORIGINATING DEPARTMENT	Pipeline
-----------------------	--------------------------------------	-------------------------------	----------

ITEM	A Resolution Awarding a Contract for Vacuum Excavation Services Resolution No. R-18-14	APPROVAL	  
-------------	---	-----------------	--

Account No: 01-60-6290

At the April 17, 2014, Commission meeting, the Board approved a Management Budget for Fiscal Year 2014-2015 which included Vacuum Excavation Services in the budgeted amount of \$90,000.00.

The purpose of this work is to visually confirm the location of Commission pipelines in certain areas where traditional methods, and conventional R/F type locating equipment, are inadequate to accurately determine the location of buried facilities. This occurs primarily in areas where pipelines were installed at depths greater than 15 feet and in congested utility corridors where electronic interference created from other utilities makes it problematic to accurately locate pipelines.

Once the location of the pipe has been visually confirmed by vacuum excavation, staff will place a 4" diameter electronic marker within the backfilled excavation. The electronic marker emits a utility specific signal capable of being detected by staff using a pipe locator tuned to that particular signal thus allowing an accurate visual marking of the pipeline to be placed on the surface.

In accordance with Article VIII Section 5 of the Commission's By-Laws, and as required by state statute, the Commission advertised for bids on two separate occasions in the *Chicago Tribune* and *The Daily Herald*. In addition, the Commission posted the advertisement on its website and solicited bids by direct invitation. Sealed bids were received until 1:00 p.m., local time, June 2, 2014, at which time all bids were publicly opened and read aloud. Of the nine proposals delivered two were received.

R.A. Mancini Inc.	\$89,925.00
Badger Daylighting	Non-responsive proposal.

The proposal of R.A Mancini Inc. was complete with no errors or omissions. The proposal of Badger Daylighting contained numerous errors and omissions including an incomplete Schedule of Prices, and contractor proposed revisions with regard to certain terms and conditions of the contract.

AGENDA SECTION	Engineering & Construction Committee	ORIGINATING DEPARTMENT	Pipeline
ITEM	A Resolution Awarding a Contract for Vacuum Excavation Services Resolution No. R-18-14	APPROVAL	
<p>In accordance with Article VIII Section 9 of the Commission's By-Laws, staff is recommending acceptance of the proposal of R.A. Mancini for Vacuum Excavation Services subject to receipt of all contractually required documentation.</p> <p>Approval of Resolution No. R-18-14 would award a Contract for Vacuum Excavation Services to R.A. Mancini Inc. for the unit prices set forth in its Contract/Proposal.</p>			
MOTION: To adopt Resolution No. R-18-14.			

DUPAGE WATER COMMISSION

RESOLUTION NO. R-18-14

A RESOLUTION AWARDING A CONTRACT FOR VACUUM EXCAVATION SERVICES

WHEREAS, pursuant to Article VIII, Section 5 of the Commission's By-Laws, and as required by State statute, the Commission solicited sealed proposals for Vacuum Excavation Services; and

WHEREAS, sealed proposals for Vacuum Excavation Services were received on June 2, 2014; and

WHEREAS, based upon staff's review of the proposals received, the Board of Commissioners of the DuPage Water Commission has determined that the proposal of R.A. Mancini Inc. was the most favorable to the interests of the Commission;

NOW, THEREFORE, BE IT RESOLVED by the Board of Commissioners of the DuPage Water Commission as follows:

SECTION ONE: The foregoing recitals are incorporated herein as findings of the DuPage Water Commission.

SECTION TWO: The DuPage Water Commission hereby awards the Contract for Vacuum Excavation Services to R.A. Mancini Inc. in accordance with its Contract/Proposal dated (June 2, 2014 , a copy of which is attached hereto and incorporated herein as Exhibit "A" conditioned upon the receipt of all contractually required documentation and such other additional information that may be requested by the General Manager of the Commission in accordance with the Commission's Request for Proposals dated May 12 2014, a copy of which is attached hereto and incorporated herein as Exhibit "B". The compensation to be paid pursuant to the Contract/Proposal incorporated herein as Exhibit "A" shall be limited to the unit prices quoted therein.

Resolution No. R-18-14

SECTION THREE: The General Manager of the Commission is hereby authorized to execute the Contract/Proposal incorporated herein as Exhibit "A", together with all other relevant contractually required documentation, on behalf of the Commission.

SECTION FOUR: This Resolution shall be in full force and effect from and after its adoption.

AYES:

NAYS:

ABSENT:

ADOPTED THIS ___ DAY OF _____, 2014

Chairman

ATTEST:

Clerk

Board/Resolutions/2014/R-18-14.docx

Exhibit A

EXHIBIT A
DUPAGE WATER COMMISSION
CONTRACT/PROPOSAL
VACUUM EXCAVATION SERVICES

Full Name of Bidder RA Mancini Inc. ("Bidder")
Principal Office Address 481 Scotland Rd, Lakemore, IL 60051
Local Office Address _____
Contact Person Mike Toniolo Telephone Number 815-344-0600

TO: DuPage Water Commission ("Owner")
600 East Butterfield Road
Elmhurst, Illinois 60126-4642
Attention: John F. Spatz, Jr.
General Manager

Bidder warrants and represents that Bidder has carefully reviewed and understood all documents included, referred to, or mentioned in this bound set of documents, including Addenda Nos. _____ [if none, write "NONE"], which are securely stapled to the end of this Contract/Proposal.

Terms defined in the Request for Proposals shall have the same meanings in all Contract Documents, including this Contract/Proposal, as ascribed to those terms in the Request for Proposals.

1. Work Proposal

A. Contract and Work. Upon the transmission of the Owner's written notification of Acceptance in the form included herein as Attachment E, Bidder proposes, and agrees, that Bidder shall, at its sole cost and expense, provide, perform, and complete, in the manner specified and described, and upon the terms and conditions set forth, in this Contract/Proposal and the remaining Contract Documents, all of the following, all of which is herein referred to as the "Work":

1. Labor, Equipment, Materials and Supplies. Provide, perform, and complete, in the manner specified and described in this Contract/Proposal, and the remaining Contract Documents, all necessary work, labor, services, transportation, equipment, materials, supplies, information, data, and other means and items necessary for Vacuum Excavation which shall be defined to be a means of soil extraction where water or an air jet is used to break up soil followed by extraction of these materials through a vacuum device.
2. Permits. Procure and furnish all permits, licenses, and other governmental approvals and authorizations necessary in connection therewith;
3. Insurance. Procure all insurance specified in this Contract/Proposal;
4. Taxes. Pay all applicable federal, state, and local taxes;

5. Miscellaneous. Do all other things required of Bidder by this Contract/Proposal; and
6. Quality. Provide, perform, and complete all of the foregoing in a proper and workmanlike manner, consistent with highest standards of professional and construction practices, in full compliance with, and as required by or pursuant, to this Contract/Proposal, and with the greatest economy, efficiency, and expedition consistent therewith, with only new, undamaged, and first quality equipment, materials, and supplies.

B. Performance Standards. If this Contract/Proposal is accepted, Bidder proposes, and agrees, that all Work shall be fully provided, performed, and completed in accordance with the Specifications attached hereto and by this reference made a part of this Contract/Proposal as Attachment A. No provision of any referenced standard, specification, manual, or code shall change the duties and responsibilities of Owner or Bidder from those set forth in these Contract Documents.

C. Responsibility for Damage or Loss. If this Contract/Proposal is accepted, Bidder proposes, and agrees, that Bidder shall be responsible and liable for, and shall promptly and without charge to Owner repair or replace, damage done to, and any loss or injury suffered by, Owner, the Work, or other property or persons as a result of the Work.

D. Inspection/Testing/Rejection. Owner shall have the right to inspect all or any part of the Work and to reject all or any part of the Work that is, in Owner's judgment, defective or damaged or that in any way fails to conform strictly to the requirements of these Contract Documents and Owner, without limiting its other rights or remedies, may require correction or replacement at Bidder's cost, perform or have performed all Work necessary to complete or correct all or any part of the Work that is defective, damaged, or nonconforming and charge Bidder with any excess cost incurred thereby, or cancel all or any part of any order or these Contract Documents. Work so rejected may be returned or held at Bidder's expense and risk.

Owner upon final acceptance of the Work by Owner.

2. Contract Price Proposal

If this Contract/Proposal is accepted, Bidder proposes, and agrees, that Bidder shall take in full payment for all Work and other matters set forth under Section 1 above, including overhead and profit; taxes, contributions, and premiums; and compensation to all subcontractors and suppliers, the compensation set forth below.

A. SCHEDULE OF PRICES

For providing, performing, and completing all Work, the sum of the products resulting from multiplying the actual number of acceptable units of Unit Price Items listed in the Schedule of Prices attached hereto as Attachment D by the Unit Price set forth the Schedule of Prices attached hereto as Attachment D for such Unit Price Item.

B. BASIS FOR DETERMINING PRICES

It is expressly understood and agreed that:

1. All prices stated in the Schedule of Prices are firm and shall not be subject to escalation or change;
2. Owner is not subject to state or local sales, use, and excise taxes, that no such taxes are included in the Schedule of Prices, and that all claim or right to claim any additional compensation by reason of the payment of any such tax is hereby waived and released;
3. All other applicable federal, state, and local taxes of every kind and nature applicable to the Work are included in the Schedule of Prices;
4. The approximate quantities set forth in the Schedule of Prices for each Unit Price Item are Owner's estimate only, that Owner reserves the right to increase or decrease such quantities and that all claim or right to dispute or complain of any such estimated quantity, or to assert that there was any misunderstanding in regard to the nature or amount of any Unit Price Item to be provided or performed, is hereby waived and released; and
5. Any items of Work not specifically listed or referred to in the Schedule of Prices, or not specifically included for payment under any Unit Price Item, shall be deemed incidental to the Contract Price, shall not be measured for payment, and shall not be paid for separately.

C. VALUE OF WORK

It is expressly understood and agreed that the value of the Work shall be determined as follows:

1. The value of Work shall be determined by Owner on the basis of the actual number of Unit Price Items acceptable to the Owner multiplied by the applicable Unit Price set forth in the Schedule of Prices attached hereto as Attachment D.
2. The Contract Price shall be adjusted to reflect the actual number Unit Price Items acceptable to

D. TIME OF PAYMENT

1. Owner shall pay to Bidder the value of Work, determined in the manner set forth above. Payment shall be in an amount equal to the sum of the number of acceptable units delivered multiplied by the per unit price and shall be made within sixty (60) days of the acceptance of the units.

3. Contract Time Proposal

If this Contract/Proposal is accepted, Bidder proposes, and agrees, that Bidder shall commence the Work within 10 days following Owner's acceptance of this Contract/Proposal (the "Commencement Date"). If this Contract/Proposal is accepted, Bidder proposes, and agrees, that Bidder shall perform the Work diligently and continuously and shall complete the Work not later than 30 calendar days following the Commencement Date.

4. Financial Assurance

A. Insurance. If this Contract/Proposal is accepted, Bidder proposes, and agrees, that Bidder will procure and maintain such insurance as will cover and include the entire obligation assumed by Bidder under the Contract Documents, as well as public liability insurance, including contractual liability, contractors liability and protective liability, automobile liability insurance, including non-owned automobile liability, and Workmen's Compensation and employer's liability insurance as will adequately protect Owner, the Work, and other property and persons against all damages, liability claims, losses and expenses (including attorney's fees) which may arise, or be alleged to have arisen, out of or in connection with Bidder's performance of, or failure to perform, the Work or any part thereof.

B. Indemnification. If this Contract/Proposal is accepted, Bidder proposes, and agrees, that Bidder shall indemnify, save harmless, and defend Owner against all damages, liability, claims, losses, and expenses (including attorneys' fees) that may arise, or be alleged to have arisen, out of or in connection with Bidder's performance of, or failure to perform, the Work or any part thereof, or any failure to meet the representations and warranties set forth in Section 6 of this Contract/Proposal.

C. Performance and Payment Bond. If this Contract/Proposal is accepted, Bidder shall with 10 days, but prior to the commencement of the Work, post with and for the benefit of the Owner a performance and payment bond on forms reasonably acceptable to the Owner in the penal sum of \$100,000.

D. Penalties. If this Contract/Proposal is accepted, Bidder proposes, and agrees, that Bidder shall be solely liable for any fines or civil penalties that are imposed by any governmental or quasi-governmental agency or body that may arise, or be alleged to have arisen, out of or in connection with Bidder's performance of, or failure to perform, the Work or any part thereof.

5. **Firm Proposal**

All prices and other terms stated in this Contract/Proposal are firm and shall not be subject to withdrawal, escalation, or change provided Owner accepts this Contract/Proposal within 60 days after the date this sealed Contract/Proposal is opened.

6. **Bidder's Representations and Warranties**

In order to induce Owner to accept this Contract/Proposal, Bidder hereby represents and warrants as follows:

A. **The Work**. The Work, and all of its components, shall be of merchantable quality; shall be free from any latent or patent defects and flaws in workmanship, materials, and design; shall strictly conform to the requirements of this Contract/Proposal and these Contract Documents, including, without limitation, the performance standards set forth in Section 1B of this Contract/Proposal; and shall be fit, sufficient, and suitable for the purposes expressed in, or reasonably inferred from, this Contract/Proposal and these Contract Documents and the warranties expressed herein shall be in addition to any other warranties expressed or implied by law, which are hereby reserved unto Owner. Bidder shall, promptly and without charge, correct any failure to fulfill the above warranty at any time within two years after final payment or such longer period as may be prescribed in the performance standards set forth in Section 1B of this Contract/Proposal, the Contract Documents or by law. The above warranty shall be extended automatically to cover all repaired and replacement parts and labor provided or performed under such warranty and Bidder's obligation to correct Work shall be extended for a period of two years from the date of such repair or replacement. The time period established in this Section 6A relates only to the specific obligation of Bidder to correct Work and shall not be construed to establish a period of limitation with respect to other obligations that Bidder has under this Contract/Proposal and the Contract Documents.

B. **Compliance with Laws**. The Work, and all of its components, shall be provided, performed, and completed in compliance with, and Bidder agrees to be bound by, all applicable federal, state, and local laws, orders, rules, and regulations, as they may be modified or amended from time to time; any statutes requiring preference to laborers of specified classes; the Illinois Steel Products Procurement Act, 30 ILCS 565/1 *et seq.*; any statutes prohibiting discrimination because of, or requiring affirmative action based on, race, creed, color, national origin, age, sex, or other prohibited classification; and any statutes regarding safety or the performance of the Work.

This Contract calls for the construction of a "public work," within the meaning of the Illinois Prevailing Wage Act, 820 ILCS 130/01 *et seq.* ("the Act"). The Act requires contractors and subcontractors to pay laborers, workers and mechanics performing services on public works projects no less than the current "prevailing rate of wages" (hourly cash wages plus amount for fringe benefits) in the county where the work is performed. The Department publishes the prevailing wage rates on its website at <http://labor.illinois.gov/>. The Department revises the prevailing wage rates and the Bidder has an obligation to check the Department's website for revisions to prevailing wage rates. For more information regarding current prevailing wage rates, please refer to the Illinois Department of Labor's website. All contractors and subcontractors rendering services under this Contract must comply with all requirements of the Act, *including but not limited to*, all wage requirements and notice and record keeping duties.

C. **Not Barred**. Bidder is not barred by law from contracting with Owner or with any other unit of state or local government for any reason, including without limitation as a result of (i) a violation of either Section 33E-3 or Section 33E-4 of Article 33 of the Criminal Code of 1961, 720 ILCS 5/33E-1 *et seq.*; or (ii) a violation of the USA Patriot Act of 2001, 107 Public Law 56 (October 26, 2001) (the "Patriot Act") or other statutes, orders, rules, and regulations of the United States government and its various executive departments, agencies and offices related to the subject matter of the Patriot Act, including, but not limited to, Executive Order 13224 effective September 24, 2001. Bidder is not acting, directly or indirectly, for or on behalf of any person, group, entity or nation named by the United States Treasury Department as a Specially Designated National and Blocked Person, or for or on behalf of any person, group, entity or nation designated in Presidential Executive Order 13224 as a person who commits, threatens to commit, or supports terrorism; and Bidder is not engaged in this transaction directly or indirectly on behalf of, or facilitating this transaction directly or indirectly on behalf of, any such person, group, entity or nation.

D. **Qualified**. Bidder has the requisite experience, ability, capital, facilities, plant, organization, and staff to enable Bidder to perform the Work successfully and promptly and to commence and complete the Work within the Contract Price and Contract Time Proposals set forth above.

In submitting this Contract/Proposal, Bidder acknowledges and agrees that:

7. **Acknowledgments**

A. **Reliance**. Owner is relying on all warranties, representations, and statements made by Bidder in this Contract/Proposal and related Contract Documents.

B. **Reservation of Rights**. Owner reserves the right to reject any and all proposals, reserves the right to reject the low price proposal, and reserves such other rights as are set forth in the Instructions to Bidders.

C. **Acceptance**. If this Contract/Proposal is accepted, Bidder shall be bound by each and every term, condition, or provision contained in this Contract/Proposal and the remaining Contract Documents including those terms contained in Owner's written notification of Acceptance attached hereto as Attachment E.

D. **Remedies**. In the event of a breach or violation of any term or condition of this Contract/Proposal or any of the other Contract Documents, Owner shall have recourse through any remedy available at law or in equity and all such remedies shall be cumulative.

E. **No Waiver**. No examination, inspection, investigation, test, measurement, review, determination, decision, certificate, or approval by Owner, whether before or after Owner's acceptance of this Contract/Proposal; nor any information or data supplied by Owner, whether before or after Owner's acceptance of this Contract/Proposal; nor any order by Owner for the payment of money; nor any payment for, or use, possession, or acceptance of, the whole or any part of the Work by Owner; nor any extension of time granted by Owner; nor any delay by Owner in exercising any right under this Contract/Proposal or other Contract Document; nor any other act or omission of Owner shall constitute or be deemed to be

an acceptance of any defective, damaged, or nonconforming Work, nor operate to waive or otherwise diminish the effect of any representation or warranty made by Bidder; or of any requirement or provision of this Contract/Proposal or other Contract Document; or of any remedy, power, or right of Owner.

F. Severability. The provisions of this Contract/Proposal together with the other Contract Documents shall be interpreted when possible to sustain their legality and enforceability as a whole. In the event any provision of this Contract/Proposal together with the other Contract Documents shall be held invalid, illegal, or unenforceable by a court of competent jurisdiction, in whole or in part, neither the validity of the remaining part of such provision, nor the validity of any other provisions of this Contract/Proposal or other Contract Documents shall be in any way affected thereby.

* G. Amendments. No modification, addition, deletion, revision, alteration, or other change to this Contract/Proposal or other Contract Documents shall be effective unless and until such change is reduced to writing and executed and delivered by Owner and Bidder.

H. Assignment. Neither this Contract/Proposal or other Contract Documents, nor any interest herein, shall be assigned or subcontracted, in whole or in part, by Bidder except upon the prior written consent of Owner.

I. Governing Law. This Contract/Proposal and other Contract Documents and the rights of the parties under this Contract/Proposal and other Contract Documents shall be interpreted according to the internal laws, but not the conflict of law rules, of the State of Illinois. Every provision of law required by law to be inserted into this Contract/Proposal or other Contract Documents shall be deemed to be inserted herein.

DATED this 2nd day of June 2014

Bidder's Status: IL Corporation () Partnership () Individual Proprietor
(State) (State)

Bidder's Name: RA Mancini Inc.

Doing Business As (if different): _____

Signature of Bidder or Authorized Agent: 

(corporate seal) Printed Name: Rich Mancini
(if corporation)

Title/Position: V-President

Bidder's Business Address: 481 Scotland Rd

Lakemoor, IL 60051

Bidder's Business Telephone: 815-344-0600 Facsimile: 815-344-0601

If a Corporation or Partnership, list all Officers or Partners:

NAME	TITLE	ADDRESS
Rich Mancini	President	481 Scotland Rd Lakemoor IL 60051
Rich Mancini	V-President	481 Scotland Rd Lakemoor IL 60051

Attachment A
SPECIFICATIONS

If the Contract/Proposal is accepted, Bidder proposes, and agrees, that all Work shall be fully provided, performed, and completed in accordance with the following specifications:

1. Scope of Work

- * A. The DuPage Water Commission (the Commission) maintains approximately 200 miles of water distribution mains located within DuPage and Cook Counties Illinois. The distribution mains are constructed of Steel Cylinder Pipe, Pre-Cast Concrete Pressure Pipe, and Ductile Iron Pipe and vary in size from 16 to 90 inches in diameter. The Commission wishes to utilize Vacuum Excavating to verify the horizontal and vertical alignment of its water distribution mains at certain locations within its distribution system generally depicted on Attachment B, and as further described in Attachment C. The excavations shall be a minimum of 8 inches in diameter, will range from approximately 5 to 20 ft in depth, and extend through various types of soil and hard surfaces.

2. Performance of the work

- A. No excavation work shall be performed without the presence of a Commission representative.
- B. The Contractor will be responsible for determining the locations of all underground utilities and shall comply with the Illinois Underground Utility Facilities Damage Prevention Act. The Contractor shall contact the State-Of Illinois One-Call Notice System, commonly referred to as J.U.L.I.E. by telephoning 811 or 1-800-892-0123 at least 48 hours prior to excavation. This work shall not be paid for separately but shall be considered as incidental to the contract.
- * C. The Contractor shall not perform, nor be compensated for, overtime work unless such overtime work has been previously authorized by the Commission in writing. For the purpose of this proposal, overtime work shall be defined as time worked in excess of a normal eight (8) hour day Monday through Friday.

3. Safety

- A. Bidder is required to independently assess the potentially hazardous conditions at the Work Site and take the necessary precautions to ensure a safe workplace pursuant to the Contract/Proposal and Bidder's legal obligations. Bidder must ensure that all personnel observe all appropriate safety precautions when working at the Work Site.
- B. Neither the Owner, nor any official or employee of the Owner, nor any authorized assistant or agent of any of them, shall be responsible for the adequacy of the Contractor's safety measures in, on, or near the Work site or sites. The Owner shall not provide design or construction review relating to the Contractor's safety precautions required for the Contractor to perform the Work.
- C. Neither the Owner, nor any official or employee of the Owner, nor any authorized assistant or agent of any of them, shall be responsible for conditions at the Work site or sites, nor for the safety of persons or property, during the performance of the Work.

4. Description of Work

- * A. The number of units paid for under Pay Item Number 1. Vacuum Excavation----Straight Time, and Pay Item Number 2. Vacuum Excavation----Overtime, when previously authorized in writing by the Commission, shall include portal to portal travel to and from the Contractor's base of operation, travel between work sites, providing traffic control and protection, if required at the work site by the permitting authority, mobilization, and de-mobilization at work sites, excavation as described in 1A. above, and offsite disposal of excavated materials.
- * B. In all cases, backfilling of the excavations shall be made by using course aggregate CA-6. The material shall be clean, dry and placed to within 6 inches of the existing surface grade immediately after excavation has been completed. Final backfill and surface restoration shall be the responsibility of the Commission. This work shall be paid for by the ton for Pay Item Number 3---CA-6 Backfill which unit price shall include

furnishing, delivering, and placement of CA-6 Backfill in the excavation to within 6 inches of existing surface grade.

5. Publicity

- A. Owner's name or insignia, photographs of the Work, or any other publicity pertaining to the Work shall not be used in any magazine, trade paper, newspaper, or other medium without the express written consent of Owner.

Attachment B

Data is for reference purposes only.
The Dupage Water Commission is
not responsible for any use of
misuse of this data.

Always call 311 or before excavating!

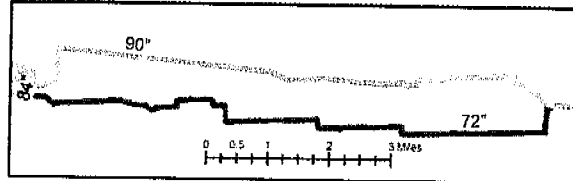
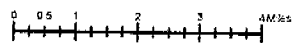
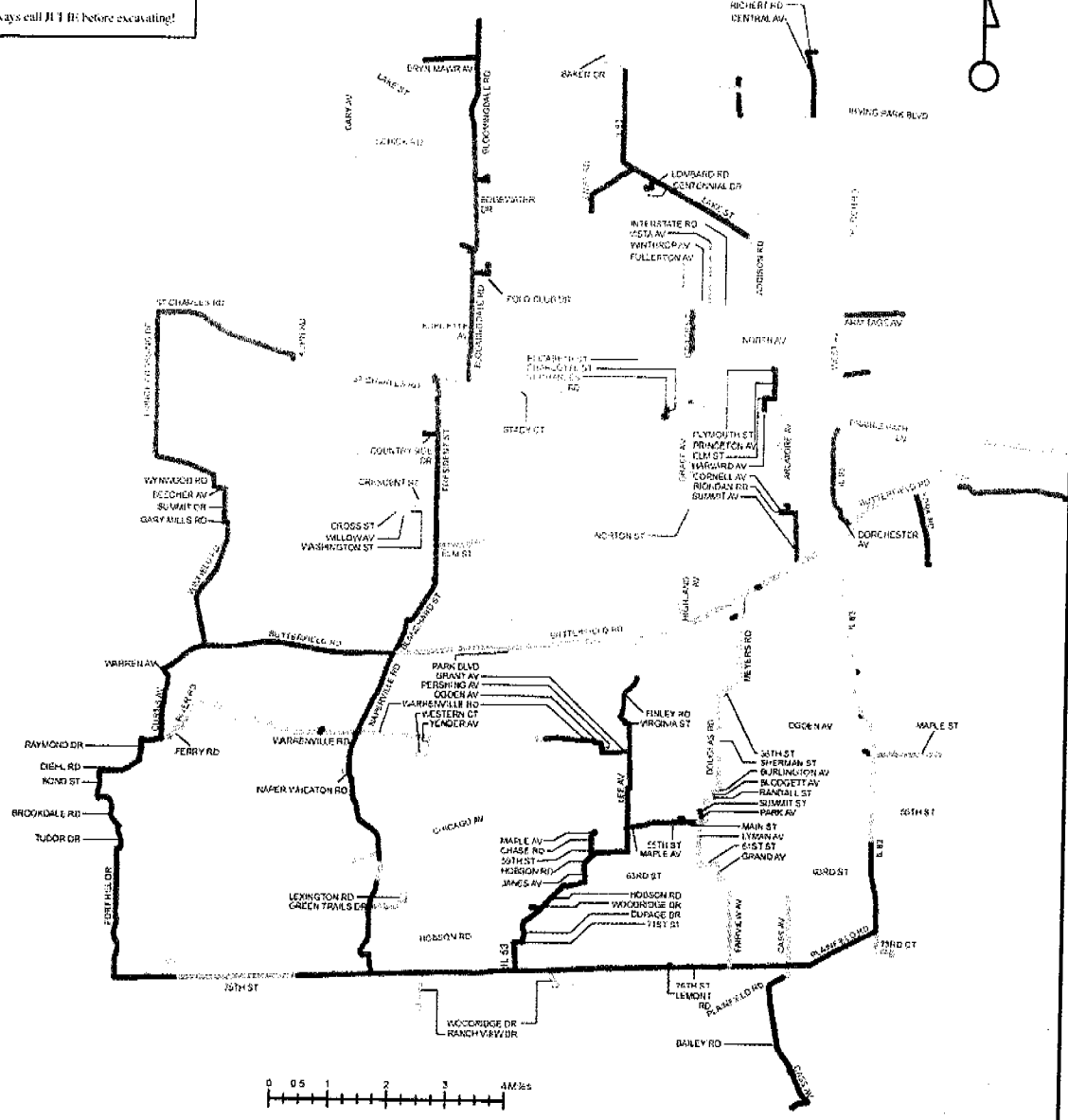
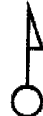

Attachment C

2-4

- 1) Butterfield Rd. 500' east of Downers Dr to I355-----^{3 LANE GOOD ACCESS}City of Downers Grove---Grass surface
- 2) Gary Ave from Schick Rd. to Scott Dr-----^{2 LANE HEAVY TRAFFIC}Village of Bloomingdale---Grass surface
- 3) Com Ed ROW from Lake St to RT53-----^{2 LANE HEAVY TRAFFIC}Village of Addison---Grass surface
- 4) Park Blvd. 1000' south of Rt.56-----^{2 LANE LIGHT TRAFFIC RESIDENTIAL COMMERCIAL}Village of Glen Ellyn---Grass and sidewalk
- 5) Naperville Rd. from RT56 north to Blanchard rd. -----City of Wheaton---Grass surface ? WHY SO FAR
- 6) Naper Blvd .from RR tracks to Plank Rd. -----City of Naperville/Village of Lisle---Grass surface
- 7) Butterfield Rd. 1000' west of Park Blvd-----^{TWO LANE}Village of Glen Ellyn---Grass surface
- 8) Roselle Rd. north of Park St-----Village of Roselle----Asphalt Roadway
- 9) Plainfield Rd. from Cass Ave to MS-----City of Darien----Grass surface
- 10) Central Ave. to Foster Ave-----City of Wood dale---Asphalt roadway
- 11) 35th St. feeder-----Village of Oakbrook---Grass surface
- 12) Naperville Rd. 1000' south of Butterfield Rd. -----City of Wheaton---Grass surface
- 13) NE corner of Naper Blvd. and Chicago Ave. -----City of Naperville/Village of Lisle---Grass surface
- 14) Lake St from JFK Dr. to creek-----Village of Addison----Grass and Sidewalk
- 15) Naperville Rd from 75th to Hobson-----City of Naperville----Grass surface
- 16) Rt83 from 22nd to Hodges Rd. -----Village of Oakbrook----Grass surface
- 17) Naper Blvd. at I-88-----City of Naperville---Grass surface
- 18) SE corner Naper Blvd. and I-88-----City of Naperville ----Grass surface

~~#14~~ 14 GRASS SURFACE

2 ASPHALT ROADWAY

2 SIDEWALK & GRASS.

Attachment D

SCHEDULE OF PRICES

If the Contract/Proposal is accepted, Bidder proposes, and agrees, that Bidder shall take in full payment for all Work and other matters set forth under Section 1 of the Contract/Proposal, including overhead and profit; taxes, contributions, and premiums; and compensation to all subcontractors and suppliers, the compensation set forth below.

For providing, performing, and completing all Work, the sum of the products resulting from multiplying the actual number of acceptable units of Unit Price Items listed below delivered to Owner by the Unit Price set forth below for such Unit Price Item:

Item No.	Description	Unit	A	B	C
			Cost Per Unit	Estimated Number of Units	(AxB) Extension
1	Vacuum Excavation----Straight Time	Hour	425 ⁰⁰	160	68,000 ⁰⁰
2	Vacuum Excavation----Overtime	Hour	475 ⁰⁰	15	7,125 ⁰⁰
3	CA-6 Backfill	Ton	74 ⁰⁰	200	14,800 ⁰⁰

TOTAL OF COLUMNS C ITEMS 1-3 Eighty Nine Thousand Nine Hundred Twenty Five Dollars and Zero Cents
 (in writing) (in writing)

89,925 Dollars and 00 Cents
 (in figures) (in figures)

B. BASIS FOR DETERMINING PRICES

It is expressly understood and agreed that:

- All prices stated in this Schedule of Prices are firm and shall not be subject to escalation or change;
- Owner is not subject to state or local sales, use, and excise taxes, that no such taxes are included in this Schedule of Prices, and that all claim or right to claim any additional compensation by reason of the payment of any such tax is hereby waived and released;
- All other applicable federal, state, and local taxes of every kind and nature applicable to the Work are included in this Schedule of Prices;
- The approximate quantities set forth in this Schedule of Prices for each Unit Price Item are Owner's estimate only, that Owner reserves the right to increase or decrease such quantities, that payment for each Unit Price Item shall be made only on the actual number of acceptable units of such Unit Price Item delivered to Owner in full compliance with the Contract/Proposal, and that all claim or right to dispute or complain of any such estimated quantity, or to assert that there was any misunderstanding in regard to the nature or amount of any Unit Price Item to be provided or performed, is hereby waived and released; and
- Any items of Work not specifically listed or referred to in this Schedule of Prices, or not specifically included for payment under any Unit Price Item, shall be deemed incidental to the Contract Price, shall not be measured for payment, and shall not be paid for separately except as incidental to the Contract Price.

Signature of Bidder or Authorized Agent: _____

Printed Name: _____

Rich Mancini

Title/Position: _____

V. President

Attachment E

ACCEPTANCE

The Contract/Proposal attached hereto and by this reference incorporated herein and made a part hereof is hereby accepted by the order of the DuPage Water Commission ("Owner") this ____ day of _____, 2014

This Acceptance, together with the Contract/Proposal attached hereto, constitutes the entire and only agreement between the parties relating to the accomplishment of the Work and the compensation therefor and supersedes and merges any other prior or contemporaneous discussions, agreements, or understandings, whether written or oral, and shall prevail over any contradictory or inconsistent terms or conditions contained in any purchase order, acceptance, acknowledgement, invoice, or other standard form used by the parties in the performance of the Contract/Proposal. Any such contradictory or inconsistent terms or conditions shall be deemed objected to by Owner without further notice of objection and shall be of no effect nor in any circumstances binding upon Owner unless accepted by Owner in a written document plainly labeled "Amendment to Contract/Proposal." Acceptance or rejection by Owner of any such contradictory or inconsistent terms or conditions shall not constitute acceptance of any other contradictory or inconsistent terms or conditions.

DUPAGE WATER COMMISSION

By: _____
John F. Spatz, Jr.
General Manager

Exhibit B

DUPAGE WATER COMMISSION

REQUEST FOR PROPOSALS

OWNER:

DuPage Water Commission
600 East Butterfield Road
Elmhurst, Illinois 60126-4642

Owner will receive sealed proposals for the Work generally described as follows:

VACUUM EXCAVATION SERVICES

TO BE SUBMITTED TO DuPage Water Commission, 600 East Butterfield Road, Elmhurst, Illinois 60126-4642, Attention John F. Spatz, Jr., General Manager, BEFORE 1:00 P.M., June 2nd, 2014.

INSTRUCTIONS TO BIDDERS

Preparation of Proposals

The "Contract Documents" shall be deemed to include this Request for Proposals and the "Contract/Proposal" attached hereto and incorporated herein as Exhibit "A" together with Attachments A through E attached thereto and incorporated therein. The "Work" shall be for "Vacuum Excavation" which shall be defined to be a means of soil extraction where water or an air jet is used to break up soil followed by extraction of these materials through a vacuum device.

All proposals for the Work shall be made only on the blank Contract/Proposal form attached to this Request for Proposals, and shall be complete with a price for each and every item named in the Schedule of Prices attached to the Contract/Proposal form as Attachment D. All proposals shall be dated on page 4 of the Contract/Proposal form and shall be signed by an authorized official, including page 5 of the Contract/Proposal form and the Schedule of Prices attached to the Contract/Proposal form as Attachment D. Proposals that contain omissions, erasures, alterations, or additions not called for, conditional or alternate bids unless called for, or that contain irregularities of any kind may be rejected.

Clarifications

Owner reserves the right to make clarifications, corrections, or changes in this Request for Proposals at any time prior to the time proposals are opened. All bidders or prospective bidders will be informed of said clarifications, corrections, or changes. If any prospective bidder has questions about this Request for Proposals, contact Ed Kazmierczak, Pipeline Supervisor, at 630-834-0100 between the hours of 7:00 AM and 3:30 PM.

Delivery of Proposals

Each proposal shall be submitted in a sealed envelope plainly marked with the title of the contract and bidder's full legal name and shall be addressed and delivered to the place and before the time set forth above. Proposals may be delivered by mail or in person. Proposals received after the time specified above will be returned unopened.

Opening of Proposals

Proposals will be publicly opened and read at the time and place specified above. Bidders, their authorized agents, and interested parties are invited to be present.

Withdrawal of Proposals

No proposal shall be withdrawn for a period of 60 days after the opening of any proposal.

Rejection of Proposals

Proposals that are not submitted on the Contract/Proposal form or that are not prepared in accordance with these Instructions to Bidders may be rejected. If not rejected, Owner may demand correction of any deficiency and accept the deficiently prepared proposal upon compliance with these Instructions to Bidders.

Acceptance of Proposals

Proposals are being solicited pursuant to, and will be acted upon, in accordance with Article VIII, Section 5 of the Owner's By-Laws. Proposals submitted are offers only and the decision to accept or reject is a function of quality, reliability, capability, reputation, and expertise of the bidders.

Owner reserves the right to accept the proposal that is, in its judgment, the best and most favorable to the interests of Owner and to the public; to reject the low price proposal; to accept any item of any proposal; to reject any and all proposals; and to waive irregularities and informalities in any proposal submitted or in the request for proposal process; provided, however, the waiver of any prior defect or informality shall not be considered a waiver of any future or similar defect or informality. Bidders should not rely upon, or anticipate, such waivers in submitting their proposal.

Owner shall notify the successful Bidder's of the acceptance of its proposal by the transmission of the Acceptance in the form attached to the Contract/Proposal as Attachment E. Upon the transmission of the Acceptance by the Owner, the Contract Documents shall become the contract for the Work.

DATED this 12th day of May 2014.

DUPAGE WATER COMMISSION

By: /s/ John F. Spatz, Jr.
General Manager

June 5, 2014

REQUEST FOR BOARD ACTION

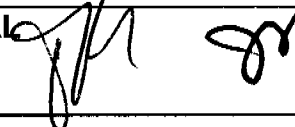
AGENDA SECTION	Engineering Committee	ORIGINATING DEPARTMENT	Operations
ITEM	Contract Agreement for Electrical Supply Consulting	APPROVAL	
<p>Agreement between DuPage Water Commission and SPI Energy Group (SPI) for consulting services at a rate of \$260.00 per hour on an as needed basis. (see attached agreement)</p> <p>The Commission has utilized the services of SPI Consulting; a recognized industry expert in the areas of bid preparation, price solicitation, and contract negotiations. While utilizing SPI consulting services, the Commission has realized substantial saving for energy supply on its last contracts (approx. 25%). The Commission also expects to see an additional saving this coming year due to the new Demand Response program.</p>			
MOTION: To Approve Contract Agreement for Electrical Supply Consulting			

CONSULTING AGREEMENT

THIS CONSULTING AGREEMENT ("Agreement") is made and entered into by and between SPI Energy Group (SPI) (the "Consultant") and the Du Page Water Commission (the "Commission") as of May 1, 2014.

WHEREAS, the Commission wishes to obtain the benefits of Consultant's experience and know-how in connection with the purchase and management of the Commission's electrical power supply; and

WHEREAS, the Commission wishes to engage Consultant to render consulting and advisory services as well as introductions and referrals of new sources of electrical power supply to the Commission on the terms and conditions set forth in this Agreement; and

WHEREAS, Consultant wishes to accept such engagement upon the terms and conditions set forth in this Agreement.

NOW, THEREFORE, in consideration of the mutual promises made by each party in this Agreement and other good and valuable consideration, the receipt and sufficiency of which is hereby acknowledged, the Commission and Consultant agree as follows:

1. Consulting Services.

- a. The Commission hereby engages Consultant as a consultant to the Commission, and Consultant hereby agrees to accept such engagement, upon the terms and conditions set forth in this Agreement. During the Term (as hereinafter defined) of this Agreement, Consultant shall:
 - i. provide support for purchase of electrical power supply
 - ii. assist in electrical power supply contract negotiations
 - iii. provide compliance support
 - iv. perform such other additional services as may be assigned to Consultant from time to time by the Commission
- b. In performance of its duties under this Agreement, Consultant shall report and be responsible only to the General Manger of the Commission and/or the General Managers designated representative, who shall be responsible for monitoring Consultant's work under this Agreement.
- c. In the performance of its duties under this Agreement, Consultant agrees that it will not:

- i. negotiate or enter into any oral or written contract, agreement, or arrangement on behalf of, or in the name of, the Commission, or otherwise bind the Commission, in any manner whatsoever;
- ii. engage in any conduct, or cause the Commission to engage in any conduct, which would result in the Commission's breach or violation of any agreement, law, ordinance, or regulation;
- iii. sign any checks on behalf of or authorize any payments by the Commission in any manner whatsoever

2. Term. The term of Consultant's retention and engagement under this Agreement shall begin on May 1, 2014 and shall end on April 30, 2015.
3. Compensation. In consideration of all services to be performed by Consultant under this Agreement, the Commission agrees to pay Consultant an hourly rate of (\$260.00). The hourly rate is subject to review annually on the anniversary date of this agreement.
4. Payment of Taxes. Consultant shall be responsible for payment of all taxes arising from Consultant's engagement under this Agreement, including federal and state income taxes and any applicable Social Security (FICA) and/or self-employment taxes. The Commission will not pay any unemployment compensation or workers' compensation taxes or premiums on behalf of Consultant, or any other taxes of any nature whatsoever.
5. Expenses. Without the prior written content of the Commission, Consultant shall be responsible for all out-of-pocket expenses including travel time that the Consultant incurs in performance of its duties under this Agreement. The Commission reserves the right to review all expenses incurred by the Consultant on the Commission's behalf. If the Commission elects to review the expenses incurred by Consultant, Consultant shall provide the Commission with a detailed expense report within ten (10) days after request by the Commission for the same.
6. Termination of Agreement. Either Party may elect to terminate this Agreement upon 30 days written notice.
7. Independent Contractor. It is understood that while this Agreement is in effect, Consultant is an independent contractor and not an employee of the Commission, and that this Agreement is not an employment agreement. Consultant shall not be deemed an employee, agent, partner or joint venture of the Commission and the Commission shall not exercise any control or

supervision with respect to Consultant's services, except to the extent that the Commission may provide specifications, descriptions, time schedules and goals for projects and exercise the right to evaluate Consultant's work product provided under this Agreement.

8. Non-Disclosure. Consultant acknowledges that in the course of the Term of this Agreement, Consultant will have access to confidential information of the Commission. Accordingly, Consultant agrees that it will not at any time, without the express prior written consent of the President of the Commission:
 - i. disclose, directly or indirectly, any confidential information to anyone outside the employ of the Commission, except as may be reasonably necessary or appropriate in connection with the performance of its duties under this Agreement; or
 - ii. use, directly or indirectly, any confidential information for the benefit of anyone other than the Commission

9. Indemnification. The Commission shall indemnify Consultant from any and all liability, expenses, and costs (including reasonable attorney's fees) resulting, directly or indirectly, from any non-compliance or breach of the terms of this Agreement by the Commission. Additionally, Consultant shall indemnify the Commission from any and all liability, expenses, and costs (including reasonable attorney's fees) resulting, directly or indirectly, from any non-compliance or breach of the terms of this Agreement by Consultant.

10. Assignability. Neither party shall assign any of its rights or obligations under this Agreement to any other person or entity without the prior written consent of the non-assigning party. This Agreement shall bind and inure to the benefit of the parties hereto and their successors and assigns.

11. Miscellaneous.
 - a. This Agreement constitutes the entire agreement of Consultant and the Commission with respect to the subject matter of this Agreement and supersedes all prior oral or written agreements between the parties in their entirety, and may not be modified or amended in any way except in writing by both parties to this Agreement. All covenants, promises and agreements set forth in the Agreement shall be binding, and apply to and inure to the benefit of the parties hereto, and their respective heirs, executors, administrators, successors and assigns
 - b. The terms of this Agreement shall be governed and construed according to the laws of the State of Illinois without regard to that state's principles regarding choice of law.

- c. If any part or parts of this Agreement are invalid or unenforceable for any reason, the remaining parts shall nevertheless be valid and enforceable.
- d. Any party's failure to enforce any of the provisions of this Agreement shall not be construed to be a waiver of such provision or of the right of that party to enforce that provision at any time thereafter. No waiver of any breach of this Agreement shall be effective unless it is in writing.

IN WITNESS WHEREOF, the parties hereto, intending to be legally bound, execute this Consulting Agreement as of the date set forth herein.

CONSULTANT:

SPI Energy Group

By:



Name:

JAMES G. BACHMAN

Title:

PRESIDENT

COMMISSION:

By:

Name:

Title:

Attachment A

SPI Energy Group

Assignments to be completed within FY2014-2015

- 1. Help facilitate the Converge Demand Response Program**
- 2. Monitor electric power supply market**
- 3. Notify the Commission if pricing incentives become available during the term of agreement**



DuPage Water Commission

MEMORANDUM

TO: John Spatz, General Manager
FROM: Cheryl Peterson, Financial Administrator *CP*
DATE: June 9, 2014
SUBJECT: Accounts Payable Listings

Following is a summary of the Accounts Payable to be considered at the June 19, 2014 Commission meeting:

May 7, 2014 to June 10, 2014 A/P Report	\$7,973,743.47
Accrued and estimated payments required before July Commission meeting	<u>833,900.00</u>
Total	<u>\$8,807,643.47</u>

cc: Chairman and Commissioners

**DUPAGE WATER COMMISSION
ITEMS TO BE PAID BY 7-17-14
Board Meeting Date: June 19, 2014**

Estimate Amount	Description	Check Number	Payment Date	Payment Amount
40,000.00	Blue Cross Blue Shield - Health Insurance			
5,500.00	Euclid Managers - Dental Insurance			
8,000.00	Illinois Public Risk Fund - Workers Comp.			
200.00	Envision Health Care - Administration Fees			
20,000.00	ComEd - Utility Charges			
300,000.00	Integrus (Exelon Energy) - Utility Charges			
180,000.00	City of Chicago - Lexington. Electric			
2,000.00	City of Naperville -Meter Station Electric Bills			
15,000.00	Nicor - Gas			
250.00	Comcast - Internet Service			
2,000.00	AT & T - Telephone Charges			
2,600.00	AT & T - Scada Backhaul Network			
1,000.00	Fed - Ex - Postage/Delivery			
8,000.00	Procurement Card Charges			
1,000.00	Home Depot - Maintenance Supplies			
550.00	Waste Management - Disposal Services			
1,500.00	Konica Minolta - Copy and Lease Charges			
350.00	Grainger - Meter Station Supplies			
2,500.00	Grainger - Supplies for Operations			
2,500.00	Grainger - Pipeline Supplies			
2,000.00	Verizon Wireless - iPad Access Fee			
3,000.00	Rory Group			
6,500.00	SPI Consulting			
1,580.00	Storino Ramello & Durkin - Professional Services			
250.00	Anderson Pest Solutions - Pest Control			
175.00	Aramark - Office Supplies			
400.00	Bedrock Earthscapes - Pond Maintenance			
125.00	Cassidy Tire - Tire Maintenance			
60.00	Ditch Witch - Vehicle Maintenance			
675.00	Eastland Industries - Blower Fan			
2,000.00	ECO Clean - Janitorial Services			
180.00	Elecsys - Data Services			
3,300.00	Farwest Corrosion Control - Pipeline Supplies			
150.00	Five Star - Oxygen Sensor			
1,325.00	Frabimor Equ. - Meter Station Supplies			

DUPAGE WATER COMMISSION
ITEMS TO BE PAID BY 7-17-14
Board Meeting Date: June 19, 2014

160.00 Garvey's - Office Supplies
550.00 Hach - Monthly and Quarterly Chemicals
1,650.00 HSQ - RTU Board Repairs
800.00 IFMA - Conference Registration
300.00 Insight Public Sector - Computer Supplies
225.00 LAI - Meter Station Supplies
50.00 McMaster Carr - Screwdriver Set
1,500.00 NSC Congress and Expo - Lodging
750.00 Office Depot - Office Supplies
50.00 Office Max - Office Supplies
45.00 Sooper Lube - Oil Change
425.00 Specialty Mat - Mat Services
250.00 Staples - Office Supplies
800.00 Stenstrom Petroleum Services - Testing
150.00 Successories - Supplies
950.00 Thermo/Cense, Inc. - Meter Station Supplies
500.00 Villa Park Electrical Supply Co - Uniforms
75.00 Ziebel - Safety Supplies
20,000.00 Divane Bros. - QRE - 6/12
60,000.00 McWilliams - QRE - 6/12
55,100.00 McWilliams - QRE - 6.003
900.00 McWilliams - QRE - 6.006
11,000.00 McWilliams - QRE - 6.008
6,000.00 John J. Millner & Assoc
15,000.00 Neri Construction - Restoration Work
25,000.00 Neri Construction - Rehabilitation Work
6,000.00 Rossi - Insurance and Bond
11,000.00 Rossi - Rehabilitation Work

833,900.00

ACCOUNTS PAYABLE
OPEN ITEM REPORT
DETAIL

VENDOR	TYPE	---ID---	ITEM DT/	DUE DT/	PAY DT/	1099	-----	DESCRIPTION	-----	GROSS/	-DISTRIBUTION-
		BANK	POST DT	DISC DT	CHECK#					BALANCE	

01-1778 ASSOCIATED TECHNICAL SERVI

INV	25013		5/20/14	5/20/14		N		LEAK LOCATING SERVICES		728.00	
OPER			5/31/14					PO: 17066		728.00	
						01	-60-6631	LEAK LOCATING SERVICES			728.00

===== TOTALS: GROSS: 728.00 PAYMENTS: 0.00 DISCS: 0.00 ADJS: 0.00 BAL: 728.00 =====

01-1397 AT&T

INV	201406054608		5/22/14	5/22/14		N		DPSS PHONE SVC: 4/23-5/22/14		397.07	
OPER			5/31/14					PO: 17070		397.07	
						01	-60-6514.01	DPSS PHONE SVC: 4/23-5/22/14			397.07

===== TOTALS: GROSS: 397.07 PAYMENTS: 0.00 DISCS: 0.00 ADJS: 0.00 BAL: 397.07 =====

01-1802 BAKER TILLY VIRCHOW KRAUSE

INV	BT750086		5/29/14	5/29/14		N		4/16-5/20/14 PROFESSIONAL SERV		2,623.50	
OPER			5/31/14					PO: 17090		2,623.50	
						01	-60-6290	4/16-5/20/14 PROFESSIONAL SERV			2,623.50

===== TOTALS: GROSS: 2,623.50 PAYMENTS: 0.00 DISCS: 0.00 ADJS: 0.00 BAL: 2,623.50 =====

01-1980 BEARY LANDSCAPING, INC.

INV	73905		5/06/14	5/06/14		N		IRRIGATION REPAIRS		725.00	
OPER			5/20/14					PO: 16608/02		725.00	
						01	-60-6290	IRRIGATION REPAIRS			325.00
						01	-60-6290	IRRIGATION REPAIRS			400.00

===== TOTALS: GROSS: 725.00 PAYMENTS: 0.00 DISCS: 0.00 ADJS: 0.00 BAL: 725.00 =====

01-2017 BEDROCK EARTHSCAPES, LLC

INV	42		6/01/14	6/01/14		N		SERVICE VISIT		1,956.00	
OPER			6/05/14					PO: 17041		1,956.00	
						01	-60-6290	SERVICE VISIT			1,956.00

===== TOTALS: GROSS: 1,956.00 PAYMENTS: 0.00 DISCS: 0.00 ADJS: 0.00 BAL: 1,956.00 =====

01-1134 CITY OF CHICAGO DEPARTMENT

INV	201406054624		5/28/14	5/28/14		N		LEXINGTON ELEC: 3/3-3/31/14		90,814.42	
OPER			5/31/14					PO: 17093		90,814.42	
						01	-60-6611.02	LEXINGTON ELEC: 3/3-3/31/14			90,814.42

INV	201406054625		5/20/14	5/20/14		N		LEX PUMP STN LABOR: APRIL 2014		27,714.62	
-----	--------------	--	---------	---------	--	---	--	--------------------------------	--	-----------	--

ACCOUNTS PAYABLE
OPEN ITEM REPORT
DETAIL

VENDOR	TYPE	---ID---	ITEM DT/	DUE DT/	PAY DT/	1099	-----	DESCRIPTION	-----	GROSS/	-DISTRIBUTION-
		BANK	POST DT	DISC DT	CHECK#					BALANCE	

01-1134 CITY OF CHICAGO DEPARTMENT** CONTINUED **

	OPER		5/31/14					PO: 17088		27,714.62	
								01 -60-6611.03	LEX PUMP STN LABOR: APRIL 2014		27,714.62

***** TOTALS: GROSS: 118,529.04 PAYMENTS: 0.00 DISCS: 0.00 ADJS: 0.00 BAL: 118,529.04 *****

01-1135 CITY OF CHICAGO SUPERINTEN

	INV	201406054626	5/31/14	5/31/14				N	WATER BILLING: MAY 2014		7,797,864.00
	OPER		5/31/14						PO: 17091		7,797,864.00
								01 -60-6611.01	WATER BILLING: MAY 2014		7,797,864.00

***** TOTALS: GROSS: 7,797,864.00 PAYMENTS: 0.00 DISCS: 0.00 ADJS: 0.00 BAL: 7,797,864.00 *****

01-2018 COMPUTER TRAINING SOURCE,

	INV	371938	5/20/14	5/20/14				N	WORDPRESS CLASS FOR RODRIGUEZ		329.00
	OPER		5/31/14						PO: 17036		329.00
								01 -60-6132	WORDPRESS CLASS FOR RODRIGUEZ		329.00

***** TOTALS: GROSS: 329.00 PAYMENTS: 0.00 DISCS: 0.00 ADJS: 0.00 BAL: 329.00 *****

01-1883 COOK COUNTY COLLECTOR

	INV	500085	6/02/14	6/02/14				N	7/1/14-6/30/15 EASEMENT AGREEM		2,995.00
	OPER		6/10/14						PO: 17101		2,995.00
								01 -60-6820	7/1/14-6/30/15 EASEMENT AGREEM		2,995.00

***** TOTALS: GROSS: 2,995.00 PAYMENTS: 0.00 DISCS: 0.00 ADJS: 0.00 BAL: 2,995.00 *****

01-1239 DIVANE BROS. ELECTRIC CO.

	INV	37925	5/02/14	5/02/14				N	QRE 6.010 REPAIRS TO ELECTRICA		1,112.75
	OPER		5/31/14						PO: 17071		1,112.75
								01 -60-6633	QRE 6.010 REPAIRS TO ELECTRICA		1,112.75

***** TOTALS: GROSS: 1,112.75 PAYMENTS: 0.00 DISCS: 0.00 ADJS: 0.00 BAL: 1,112.75 *****

01-1915 DOUGLAS R. ELLSWORTH

	INV	201406054629	6/01/14	6/01/14				Y	SERV AS TREAS: JUNE 2014		1,666.67
	OPER		6/05/14						PO: 17092		1,666.67
								01 -60-6111	SERV AS TREAS: JUNE 2014		1,666.67

***** TOTALS: GROSS: 1,666.67 PAYMENTS: 0.00 DISCS: 0.00 ADJS: 0.00 BAL: 1,666.67 *****

01-1674 ECO PROMOTIONAL PRODUCTS,

	INV	13422	5/30/14	5/30/14				N	PROMOTIONAL PRODUCTS		3,776.54
--	-----	-------	---------	---------	--	--	--	---	----------------------	--	----------

ACCOUNTS PAYABLE
OPEN ITEM REPORT
DETAIL

VENDOR	TYPE	---ID---	ITEM DT/	DUE DT/	PAY DT/	1099	-----	DESCRIPTION	-----	GROSS/	-DISTRIBUTION-
		BANK	POST DT	DISC DT	CHECK#					BALANCE	

01-1674 ECO PROMOTIONAL PRODUCTS, ** CONTINUED **

	OPER		5/31/14					PO: 17075		3,776.54			
								01 -60-6210	PROMOTIONAL PRODUCTS		3,776.54		
===== TOTALS:			GROSS:	3,776.54	PAYMENTS:	0.00	DISCS:	0.00	ADJS:	0.00	BAL:	3,776.54	=====

01-1569 EDWARD COUGHLIN

CM	201406094632		5/28/14	5/28/14		Y		REVERSE SECURITY: 5/15/14		75.00CR			
	OPER		5/31/14					PO: 17061		75.00CR			
								01 -60-6591	REVERSE SECURITY: 5/15/14		75.00CR		
INV	201406054615		5/28/14	5/28/14		Y		SECURITY: 5/15/14		75.00			
	OPER		5/31/14					PO: 17061		75.00			
								01 -60-6591	SECURITY: 5/15/14		75.00		
INV	201406094633		5/28/14	5/28/14		Y		SECURITY: 5/15/14		75.00			
	OPER		5/31/14					PO: 17061		75.00			
								01 -60-6191	SECURITY: 5/15/14		75.00		
===== TOTALS:			GROSS:	75.00	PAYMENTS:	0.00	DISCS:	0.00	ADJS:	0.00	BAL:	75.00	=====

01-1892 GORSKI & GOOD, LLP

INV	201406054627		5/31/14	5/31/14		Y		ATTORNEY FEE: MAY 2014		2,480.00			
	OPER		5/31/14					PO: 17096		2,480.00			
								01 -60-6251	ATTORNEY FEE: MAY 2014		1,580.00		
								01 -2612.09	ATTORNEY FEE: MAY 2014		900.00		
								01 -60-7112.01	ATTORNEY FEE: MAY 2014		900.00		
								01 -5920	ATTORNEY FEE: MAY 2014		900.00CR		
===== TOTALS:			GROSS:	2,480.00	PAYMENTS:	0.00	DISCS:	0.00	ADJS:	0.00	BAL:	2,480.00	=====

01-1055 GRAINGER

INV	9446961659		5/21/14	6/20/14		N		MAINTENANCE SUPPLIES		89.30	
	OPER		5/31/14					PO: 17040		89.30	
								01 -60-6560	MAINTENANCE SUPPLIES		89.30
INV	9448005406		5/22/14	6/21/14		N		MAINTENANCE SUPPLIES		477.06	
	OPER		5/31/14					PO: 17040		477.06	
								01 -60-6560	MAINTENANCE SUPPLIES		477.06
INV	9452989917		5/29/14	6/28/14		N		MAINTENANCE SUPPLIES		60.39	
	OPER		5/31/14					PO: 17073		60.39	
								01 -60-6560	MAINTENANCE SUPPLIES		60.39
INV	9454364143		5/30/14	6/29/14		N		MAINTENANCE SUPPLIES		66.62	
	OPER		5/31/14					PO: 17082		66.62	

ACCOUNTS PAYABLE
OPEN ITEM REPORT
DETAIL

VENDOR	TYPE	---ID---	ITEM DT/	DUE DT/	PAY DT/	1099	-----	DESCRIPTION	-----	GROSS/	-DISTRIBUTION-		
		BANK	POST DT	DISC DT	CHECK#					BALANCE			
01-1604	MWH AMERICAS, INC.		** CONTINUED **										
	OPER		5/31/14					PO: 17034		5,162.86			
								01 -60-6210	WATER CONSERVATION PLAN		5,162.86		
===== TOTALS:			GROSS:	5,162.86	PAYMENTS:	0.00	DISCS:	0.00	ADJS:	0.00	BAL:	5,162.86	=====
01-1889	PALATINE OIL CO., INC.												
	INV 667728		5/09/14	5/09/14		N		GASOLINE		2,448.86			
	OPER		5/31/14					PO: 17046		2,448.86			
								01 -60-6642	GASOLINE		2,448.86		
===== TOTALS:			GROSS:	2,448.86	PAYMENTS:	0.00	DISCS:	0.00	ADJS:	0.00	BAL:	2,448.86	=====
01-1664	PROGRAM ONE PROFESSIONAL B												
	INV 59045		4/30/14	4/30/14		N		WINDOW CLEANING: 4/21/14		454.28			
	OPER		6/10/14					PO: 17103		454.28			
								01 -60-6290	WINDOW CLEANING: 4/21/14		454.28		
	INV 59646		5/30/14	5/30/14		N		WINDOW CLEANING: 5/27/14		1,092.62			
	OPER		6/10/14					PO: 17102		1,092.62			
								01 -60-6290	WINDOW CLEANING: 5/27/14		1,092.62		
===== TOTALS:			GROSS:	1,546.90	PAYMENTS:	0.00	DISCS:	0.00	ADJS:	0.00	BAL:	1,546.90	=====
01-1679	PURSUIT LIGHTING & COMMUNI												
	INV 00179		5/22/14	5/22/14		N		TRUCK 44 REPAIRS		160.90			
	OPER		6/10/14					PO: 17107		160.90			
								01 -60-6641	TRUCK 44 REPAIRS		160.90		
===== TOTALS:			GROSS:	160.90	PAYMENTS:	0.00	DISCS:	0.00	ADJS:	0.00	BAL:	160.90	=====
01-1059	RED WING SHOE STORE												
	INV 450000007172		5/28/14	6/27/14		N		SAFETY SHOES: JULIEN, CUVALO, RO		566.00			
	OPER		5/31/14					PO: 17012/05		566.00			
								01 -60-6626	SAFETY SHOES: JULIEN, CUVALO, RO		566.00		
===== TOTALS:			GROSS:	566.00	PAYMENTS:	0.00	DISCS:	0.00	ADJS:	0.00	BAL:	566.00	=====
01-1679	REED & ASSOCIATES LTD.												
	INV 2837		6/04/14	6/04/14		N		TECHNICAL WRITING SERVICES		742.50			
	OPER		6/10/14					PO: 17105		742.50			
								01 -60-6280	TECHNICAL WRITING SERVICES		742.50		
===== TOTALS:			GROSS:	742.50	PAYMENTS:	0.00	DISCS:	0.00	ADJS:	0.00	BAL:	742.50	=====

ACCOUNTS PAYABLE
OPEN ITEM REPORT
DETAIL

VENDOR	TYPE	---ID---	ITEM DT/	DUE DT/	PAY DT/	1099	-----	DESCRIPTION	-----	GROSS/	-DISTRIBUTION-
		BANK	POST DT	DISC DT	CHECK#					BALANCE	

01-1813 ROESCH FORD

INV	FOCQ53267		5/15/14	5/15/14		N		VEHICLE REPAIRS: M169815		458.96	
OPER			5/31/14					PO: 17023		458.96	
						01	-60-6641	VEHICLE REPAIRS: M169815			458.96

***** TOTALS: GROSS: 458.96 PAYMENTS: 0.00 DISCS: 0.00 ADJS: 0.00 BAL: 458.96 *****

01-1903 ROWELL CHEMICAL CORPORATIO

INV	1237581		6/05/14	6/05/14		N		SODIUM HYPOCHLORITE		2,756.43	
OPER			6/10/14					PO: 17072		2,756.43	
						01	-60-6613	SODIUM HYPOCHLORITE			2,756.43

***** TOTALS: GROSS: 2,756.43 PAYMENTS: 0.00 DISCS: 0.00 ADJS: 0.00 BAL: 2,756.43 *****

01-1715 SIKTCH

INV	187529		5/14/14	5/14/14		N		AUDIT SERVICES: FY 2014		6,500.00	
OPER			5/31/14					PO: 17039		6,500.00	
						01	-60-6260	AUDIT SERVICES: FY 2014			6,500.00

***** TOTALS: GROSS: 6,500.00 PAYMENTS: 0.00 DISCS: 0.00 ADJS: 0.00 BAL: 6,500.00 *****

01-1043 SOOPER LUBE

INV	241845		5/22/14	5/22/14		N		VEHICLE MAINT: M66159		35.95	
OPER			6/10/14					PO: 17058		35.95	
						01	-60-6641	VEHICLE MAINT: M66159			35.95

***** TOTALS: GROSS: 35.95 PAYMENTS: 0.00 DISCS: 0.00 ADJS: 0.00 BAL: 35.95 *****

01-2004 STORINO RAMELLO & DURKIN

INV	64277		5/01/14	5/01/14		N		LEGAL- LOCAL 399 NEG FOR 2014		767.55	
OPER			5/31/14					PO:		767.55	
						01	-60-6253	LEGAL- LOCAL 399 NEG FOR 2014			767.55

INV	64278		5/01/14	5/01/14		N		LEGAL- LOCAL 150 NEG FOR 2014		139.75	
OPER			5/31/14					PO:		139.75	
						01	-60-6253	LEGAL- LOCAL 150 NEG FOR 2014			139.75

***** TOTALS: GROSS: 907.30 PAYMENTS: 0.00 DISCS: 0.00 ADJS: 0.00 BAL: 907.30 *****

01-1538 TANK INDUSTRY CONSULTANTS,

INV	30497		5/09/14	5/09/14		N		STANDPIPE REHAB PROJECT		10,246.50	
OPER			5/20/14					PO: 17032		10,246.50	

ACCOUNTS PAYABLE
OPEN ITEM REPORT
DETAIL

VENDOR	TYPE	---ID---	ITEM DT/	DUE DT/	PAY DT/	1099	-----	DESCRIPTION	-----	GROSS/	-DISTRIBUTION-
		BANK	POST DT	DISC DT	CHECK#					BALANCE	

01-1538	TANK INDUSTRY CONSULTANTS,** CONTINUED **							01 -60-7707.01	STANDPIPE REHAB PROJECT		10,246.50
---------	---	--	--	--	--	--	--	----------------	-------------------------	--	-----------

***** TOTALS: GROSS: 10,246.50 PAYMENTS: 0.00 DISCS: 0.00 ADJS: 0.00 BAL: 10,246.50 *****

01-1427 VILLA PARK ELECTRICAL SUPP

INV	01838286		5/01/14	6/30/14		N		UNIFORMS		144.00	
	OPER		5/31/14					PO: 17042		144.00	
							01 -60-6626	UNIFORMS			144.00
INV	01838752		5/08/14	6/30/14		N		UNIFORMS		147.40	
	OPER		5/31/14					PO: 17042		147.40	
							01 -60-6626	UNIFORMS			147.40
INV	01839060		5/12/14	6/30/14		N		UNIFORMS		76.80	
	OPER		5/31/14					PO: 17042		76.80	
							01 -60-6626	UNIFORMS			76.80
INV	01839655		5/21/14	6/30/14		N		UNIFORMS		19.47	
	OPER		5/31/14					PO: 17065		19.47	
							01 -60-6626	UNIFORMS			19.47
INV	01839658		5/21/14	6/30/14		N		UNIFORMS		93.00	
	OPER		5/31/14					PO: 17065		93.00	
							01 -60-6626	UNIFORMS			93.00
INV	01839659		5/21/14	6/30/14		N		UNIFORMS		124.70	
	OPER		5/31/14					PO: 17065		124.70	
							01 -60-6626	UNIFORMS			124.70
INV	01839660		5/21/14	6/30/14		N		UNIFORMS		62.80	
	OPER		5/31/14					PO: 17065		62.80	
							01 -60-6626	UNIFORMS			62.80
INV	01839661		5/21/14	6/30/14		N		UNIFORMS		58.00	
	OPER		5/31/14					PO: 17065		58.00	
							01 -60-6626	UNIFORMS			58.00
INV	01839662		5/21/14	6/30/14		N		UNIFORMS		19.40	
	OPER		5/31/14					PO: 17065		19.40	
							01 -60-6626	UNIFORMS			19.40
INV	01839663		5/21/14	6/30/14		N		UNIFORMS		165.10	
	OPER		5/31/14					PO: 17065		165.10	
							01 -60-6626	UNIFORMS			165.10
INV	01839664		5/21/14	6/30/14		N		UNIFORMS		58.00	
	OPER		5/31/14					PO: 17065		58.00	

ACCOUNTS PAYABLE
OPEN ITEM REPORT
DETAIL

VENDOR	TYPE	---ID---	ITEM DT/	DUE DT/	PAY DT/	1099	-----	DESCRIPTION	-----	GROSS/	-DISTRIBUTION-
	BANK		POST DT	DISC DT	CHECK#					BALANCE	

01-1427 VILLA PARK ELECTRICAL SUPP** CONTINUED **

							01	-60-6626	UNIFORMS		58.00
INV	01839665		5/21/14	6/30/14		N		UNIFORMS		77.40	
	OPER		5/31/14					PO: 17065		77.40	
							01	-60-6626	UNIFORMS		77.40
INV	01839666		5/21/14	6/30/14		N		UNIFORMS		62.80	
	OPER		5/31/14					PO: 17065		62.80	
							01	-60-6626	UNIFORMS		62.80

===== TOTALS: GROSS: 1,108.87 PAYMENTS: 0.00 DISCS: 0.00 ADJS: 0.00 BAL: 1,108.87 =====

01-1131 VILLA PARK OFFICE EQUIPMEN

INV	49015		5/20/14	6/19/14		N		OFFICE EQUIPMENT		985.00	
	OPER		5/31/14					PO: 17030		985.00	
							01	-60-6591	OFFICE EQUIPMENT		985.00
INV	49054		5/22/14	6/21/14		N		OFFICE EQUIPMENT		257.00	
	OPER		5/31/14					PO: 17000		257.00	
							01	-60-6591	OFFICE EQUIPMENT		257.00

===== TOTALS: GROSS: 1,242.00 PAYMENTS: 0.00 DISCS: 0.00 ADJS: 0.00 BAL: 1,242.00 =====

ACCOUNTS PAYABLE
OPEN ITEM REPORT
DETAIL

TOTALS

	GROSS	PAYMENTS	BALANCE
PAID ITEMS	0.00	0.00	0.00
PARTIALLY PAID	0.00	0.00	0.00
UNPAID ITEMS	7,973,743.47	0.00	7,973,743.47
** TOTALS **	7,973,743.47	0.00	7,973,743.47

O P E N I T E M R E P O R T

D E T A I L

** PRE-PAID INVOICES **

P R E P A I D T O T A L S

	GROSS	PAYMENTS	BALANCE
PAID ITEMS	0.00	0.00	0.00
PARTIALLY PAID	0.00	0.00	0.00
UNPAID ITEMS	0.00	0.00	0.00
** TOTALS **	0.00	0.00	0.00

A C C O U N T S P A Y A B L E
O P E N I T E M R E P O R T
D E T A I L

R E P O R T T O T A L S

	GROSS	PAYMENTS	BALANCE
PAID ITEMS	0.00	0.00	0.00
PARTIALLY PAID	0.00	0.00	0.00
UNPAID ITEMS	7,973,743.47	0.00	7,973,743.47
VOIDED ITEMS	0.00	0.00	0.00
** TOTALS **	7,973,743.47	0.00	7,973,743.47

U N P A I D R E C A P

NUMBER OF HELD INVOICES	0
UNPAID INVOICE TOTALS	7,974,845.87
UNPAID DEBIT MEMO TOTALS	0.00
UNAPPLIED CREDIT MEMO TOTALS	1,102.40-
** UNPAID TOTALS **	7,973,743.47

G/L EXPENSE DISTRIBUTION

ACCOUNT NUMBER	ACCOUNT NAME	AMOUNT
01 2612.09	CNST DEP - YORK METER STATION	900.00
01 5920	CONTRIBUTIONS	900.00CR
01 60-6111	ADMIN SALARIES	1,666.67
01 60-6132	TRAINING	329.00
01 60-6133.01	CONFERENCES	53.00
01 60-6191	OTHER PERSONNEL COSTS	75.00
01 60-6210	WATER CONSERVATION PROGRAM	8,939.40
01 60-6251	LEGAL SERVICES- GENERAL	1,580.00
01 60-6253	LEGAL SERVICES- SPECIAL	907.30
01 60-6260	AUDIT SERVICES	6,500.00
01 60-6280	CONSULTING SERVICES	742.50
01 60-6290	CONTRACTUAL SERVICES	9,295.29
01 60-6514.01	TELEPHONE	397.07
01 60-6560	REPAIRS & MAINT- BLDGS & GRN	693.37
01 60-6591	OTHER ADMINISTRATIVE EXPENSE	1,242.00
01 60-6611.01	WATER BILLING	7,797,864.00
01 60-6611.02	ELECTRICITY	90,814.42
01 60-6611.03	OPERATIONS & MAINTENANCE	27,714.62

A C C O U N T S P A Y A B L E
O P E N I T E M R E P O R T
D E T A I L

G/L EXPENSE DISTRIBUTION

ACCOUNT NUMBER	ACCOUNT NAME	AMOUNT
01 60-6613	WATER CHEMICALS	2,756.43
01 60-6624	SCADA / INSTRUMENTATION	2,270.00
01 60-6626	UNIFORMS	1,674.87
01 60-6627	SAFETY	1,027.40CR
01 60-6631	PIPELINE REPAIRS	728.00
01 60-6633	REMOTE FACILITIES MAINTENANCE	1,281.76
01 60-6641	REPAIRS & MAINT- VEHICLES	655.81
01 60-6642	FUEL- VEHICLES	2,448.86
01 60-6820	PERMITS & FEES	2,995.00
01 60-7112.01	DPC YORK MS-CONSTR	900.00
01 60-7707.01	STANDPIPE PAINTING-CONSTR	10,246.50
	** FUND TOTAL **	7,973,743.47

	** TOTAL **	7,973,743.47
--	-------------	--------------

ACCOUNTS PAYABLE
OPEN ITEM REPORT
DETAIL

DEPARTMENT TOTALS

DEPARTMENT	DEPARTMENT NAME	AMOUNT
01	NON-DEPARTMENTAL	900.00
01 59	INVALID DEPARTMENT	900.00CR
01 60	ADMINISTRATION	7,973,743.47
	** FUND TOTAL **	7,973,743.47

	** TOTAL **	7,973,743.47
--	-------------	--------------

0 ERRORS
1 WARNINGS

SELECTION CRITERIA

VENDOR SET: 01-DUPAGE WATER COMMISSION
 VENDOR: THRU ZZZZZZ
 VENDOR CLASS: ALL
 BANK CODES: Include: OPER
 1099 BOX: All
 COMMENT CODES: All
 HOLD STATUS: Both
 AP BALANCE AS OF: 0/00/0000
 ADVANCED SELECTION: Yes

ITEM SELECTION: UNPAID ITEMS
 FUNDS: All
 ACCOUNT RANGE: THRU ZZZZZZZZZZZZZZZZZ
 ITEM AMOUNT: 9,999,999.00CR THRU 9,999,999.00

PRINT OPTIONS:

SEQUENCE: VENDOR SORT KEY
 REPORT TYPE: DETAIL
 SORT TRANSACTIONS BY DATE: NO
 G/L ACCOUNTS/PROJECTS: YES
 ONE VENDOR PER PAGE: NO
 ONE DEPARTMENT PER PAGE: NO
 PRINT STUB COMMENTS: NO
 PRINT COMMENT CODES: None
 PRINT W/ PO ONLY: No

DATE SELECTION:

PAYMENT DATE: 0/00/0000 THRU 99/99/9999
 ITEM DATE: 0/00/0000 THRU 99/99/9999
 POSTING DATE: 5/07/2014 THRU 6/10/2014



DuPage Water Commission

MEMORANDUM

TO: Chairman Zay and Commissioners

FROM: John F. Spatz
General Manager

A handwritten signature in black ink, appearing to be "JF Spatz", is written to the right of the name "John F. Spatz".

DATE: June 12, 2014

SUBJECT: May 1, 2014 Invoice

I reviewed the Storino Ramello & Durkin April 2014 invoice for services rendered during the period April 4, 2014 – April 30, 2014 and recommend it for approval. This invoice should be placed on the June 19, 2014, Commission meeting accounts payable.

May 1, 2014
Storino Ramello & Durkin

CATEGORY	<u>FEES</u>	<u>HOURS BILLED</u>	<u>AVERAGE HOURLY RATE</u>	<u>ATTORNEYS & PARALEGALS EMPLOYED</u>	<u>MAJOR ACTIVITIES</u>
General	\$907.30	4.22	\$215.00	Durkin (4.22 @ \$215/hr.)	Discussion regarding Collective Bargaining Agreements for Local 150 and 399
Misc:	<u>\$0.00</u>				
	<u>\$907.30</u>	<u>4.22</u>	<u>\$215.00</u>		



DuPage Water Commission

MEMORANDUM

TO: Chairman Zay and Commissioners

FROM: John F. Spatz
General Manager 

DATE: June 12, 2014

SUBJECT: May 2014 Invoice

I reviewed the Gorski & Good, LLP April 2014 invoice for services rendered during the period – May 2, 2014 – May 21, 2014 and recommend it for approval. This invoice should be placed on the June 19, 2014, Commission meeting accounts payable.

May 2014
Gorski & Good

CATEGORY	<u>FEEES</u>	<u>HOURS BILLED</u>	<u>AVERAGE HOURLY RATE</u>	<u>ATTORNEYS & PARALEGALS EMPLOYED</u>	<u>MAJOR ACTIVITIES</u>
General	\$2,480.00	12.40	\$200.00	Gorski (3.0 @ \$200/hr.) Good (6.6 @\$200/hr.); Jones (2.8 @ \$200/hr.)	various (review board packet material, agreements, contracts, proposed legislation, and attend regular Commission Meeting
Misc:	<u>\$0.00</u>	<u></u>	<u></u>		
	<u>\$2,480.00</u>	<u>12.40</u>	<u>\$200.00</u>		